

# Modelling Urban Public Transportation Networks to Support Robust Routing

Kateřina Böhmová, Matúš Mihalák, Tobias Pröger, Peter Widmayer

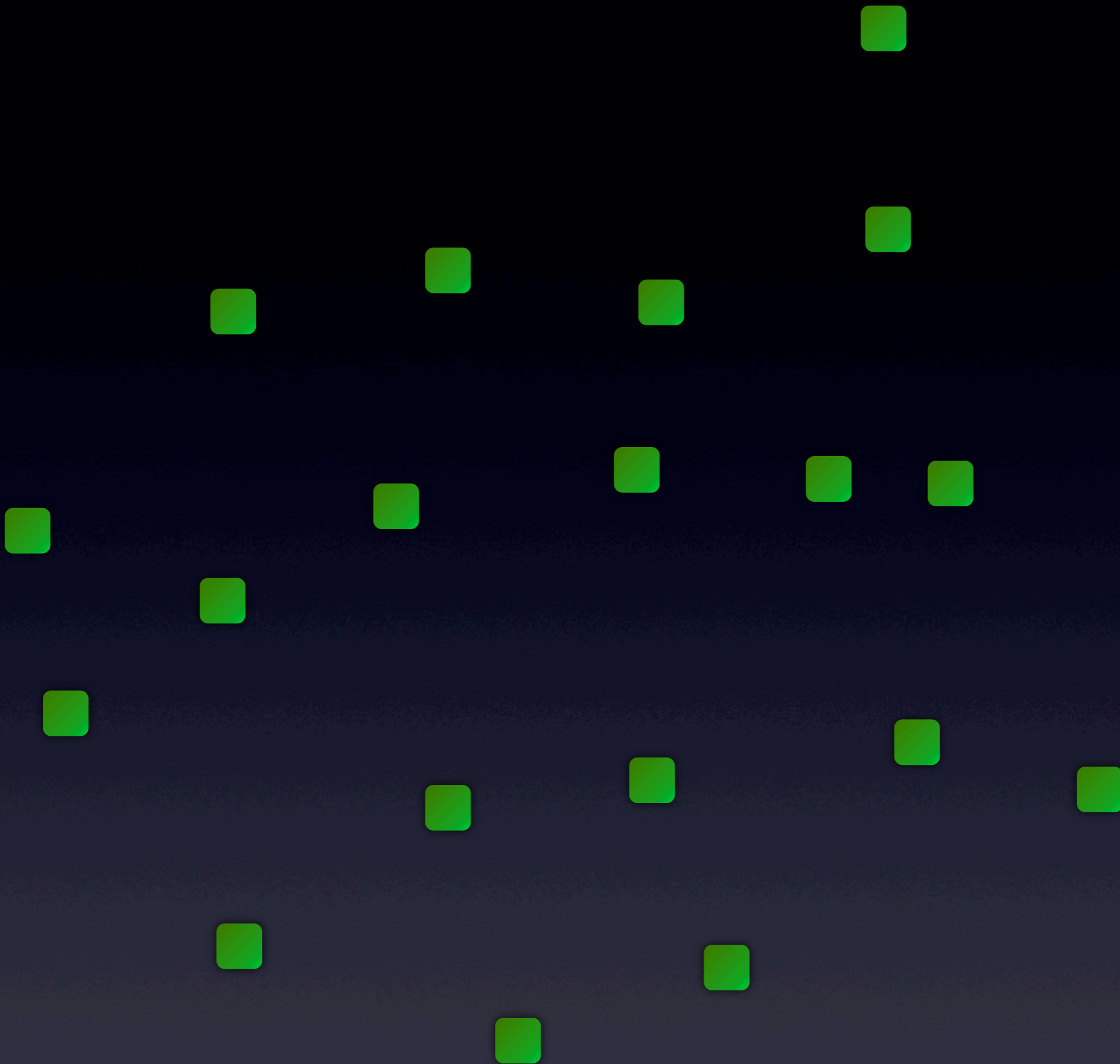

Stops



Stops

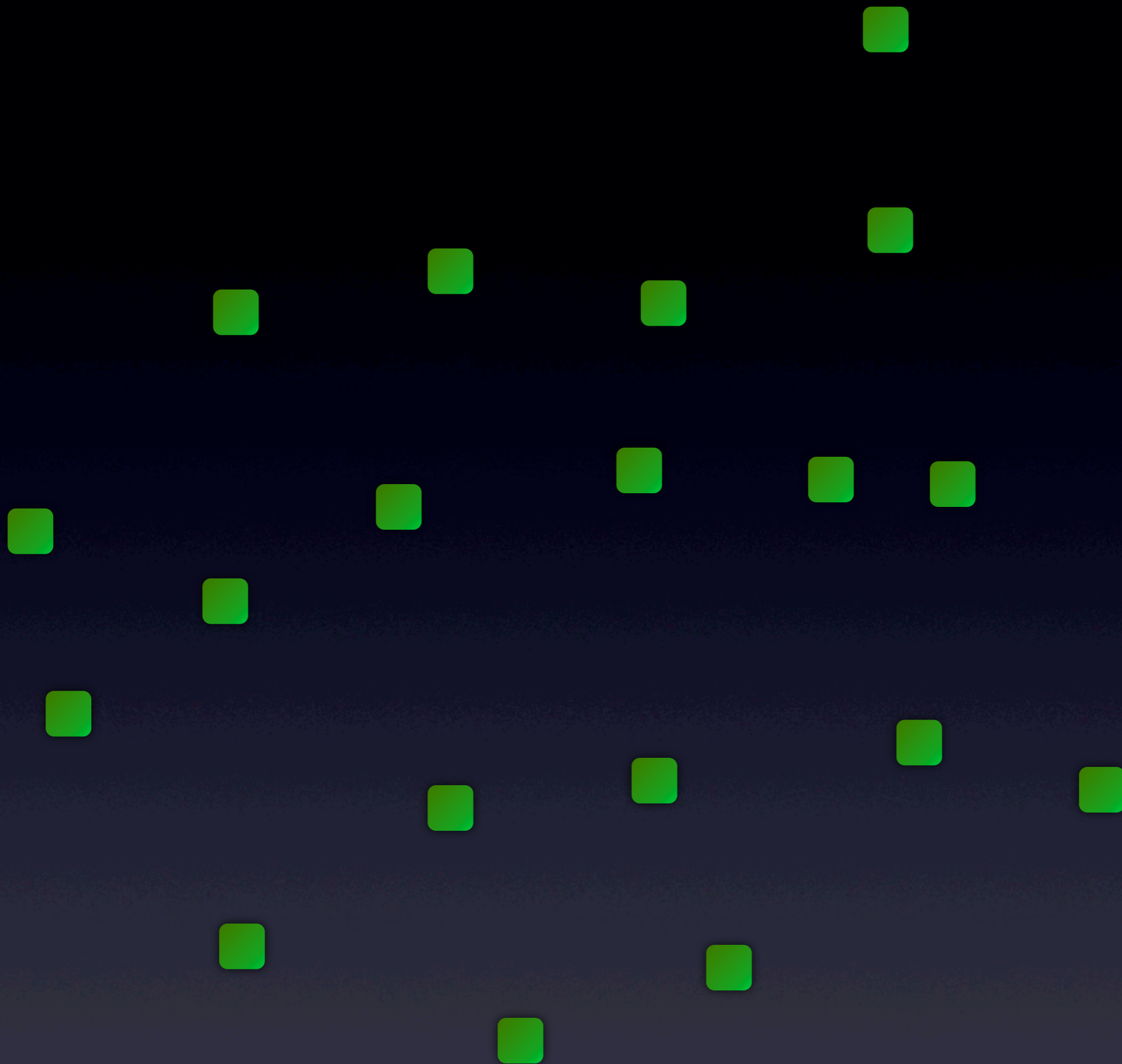

Stops

Lines

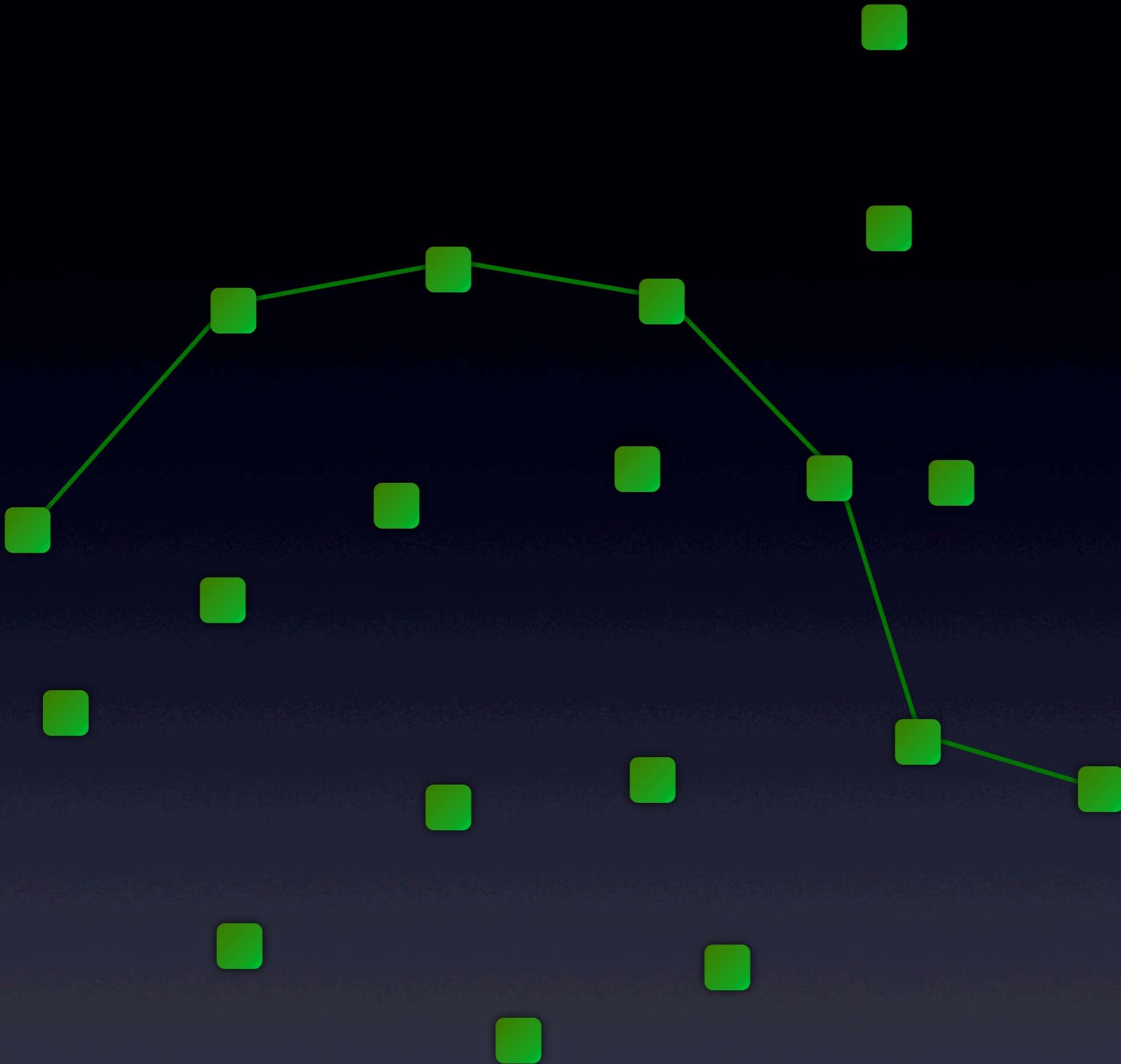

Stops

Lines

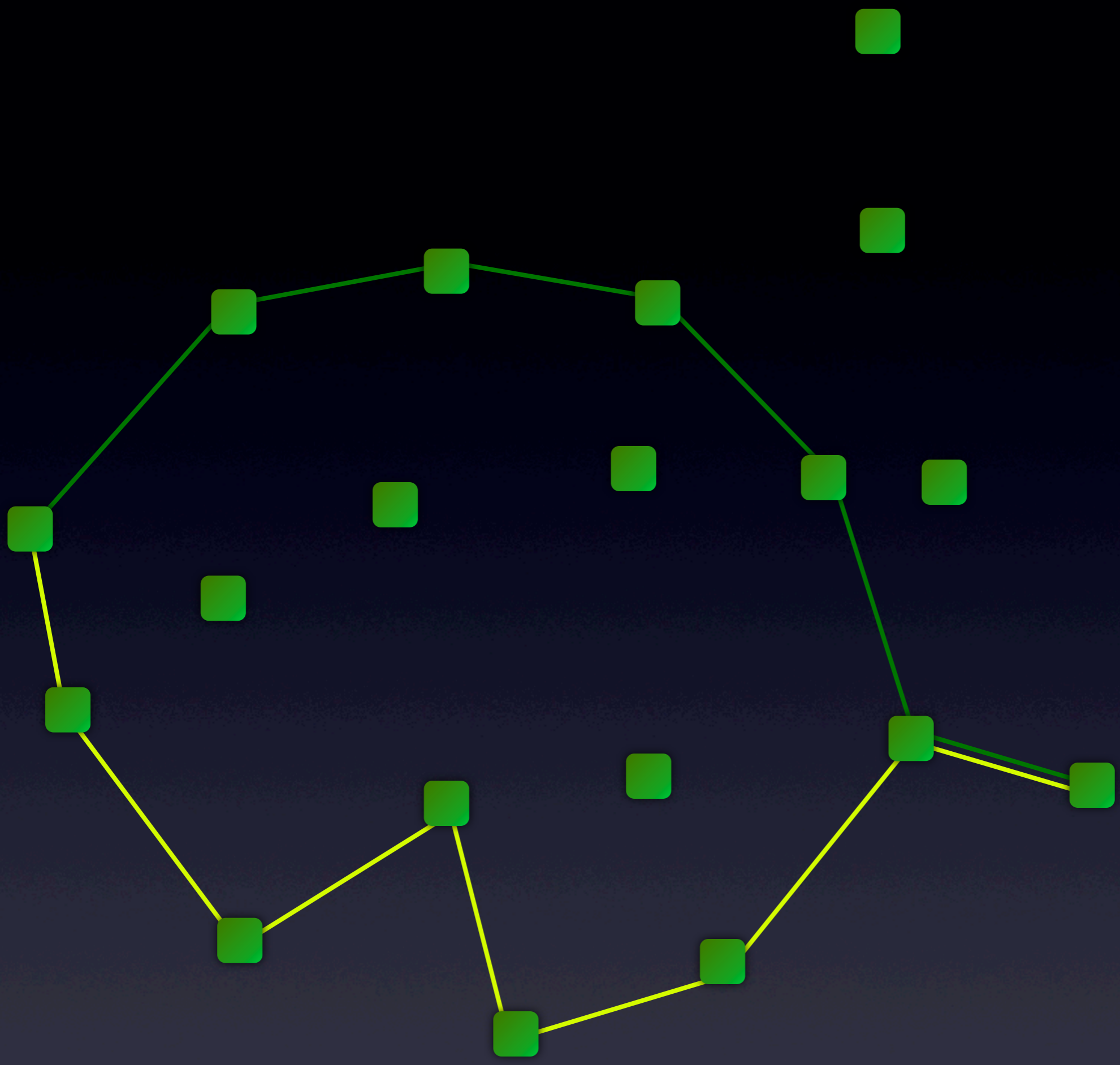

Stops

Lines

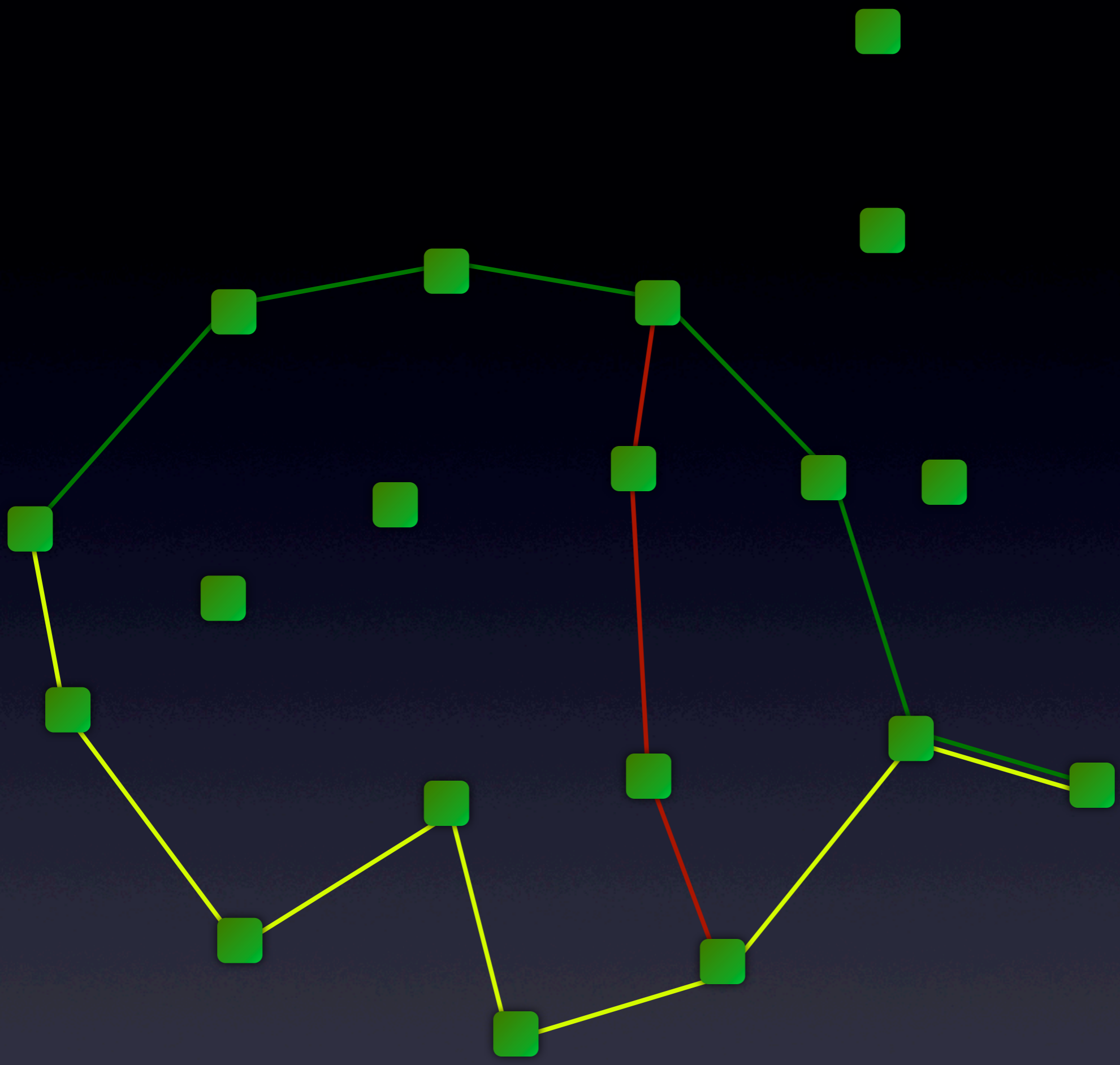

Stops  
Lines



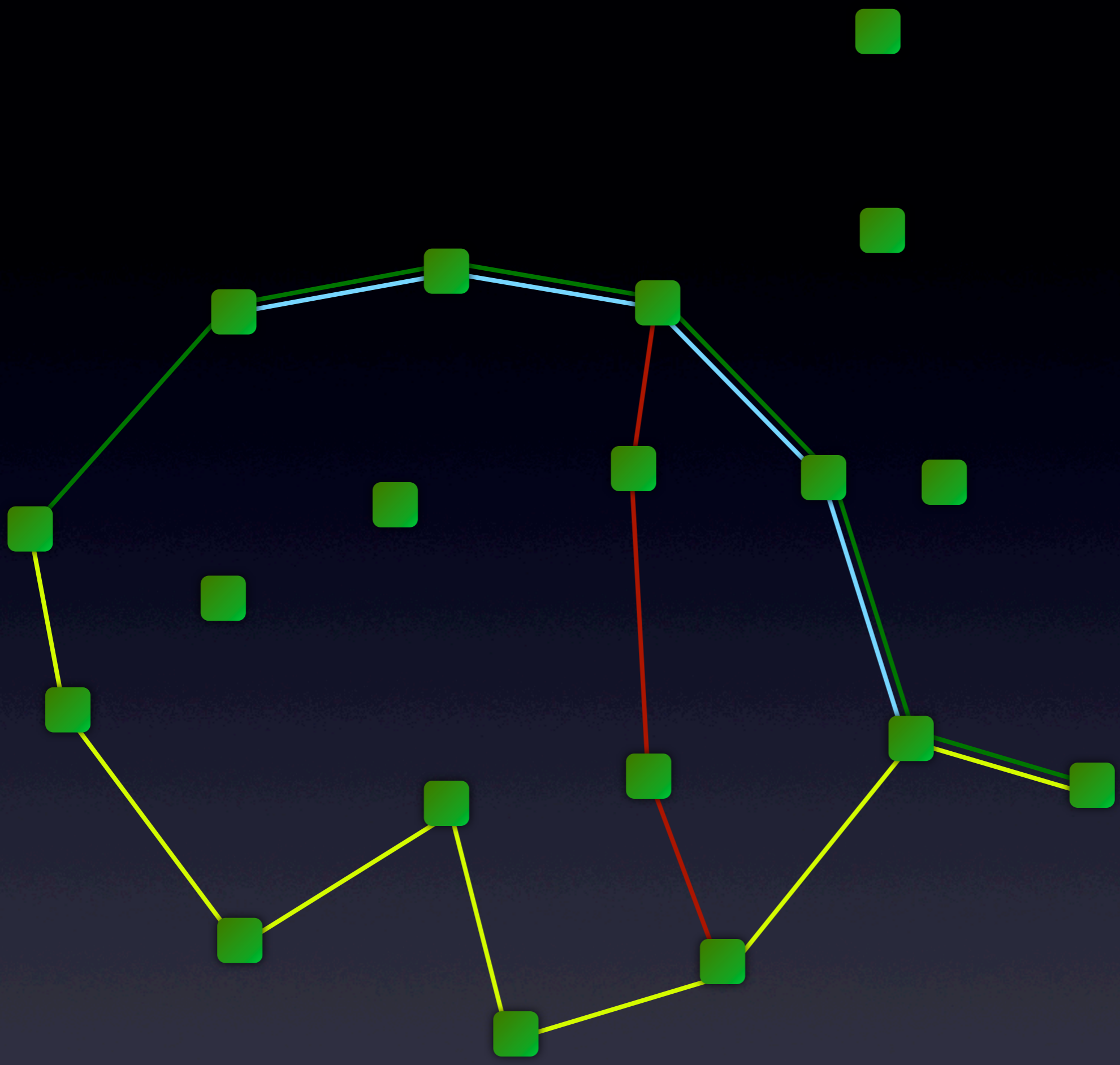

Stops

Lines

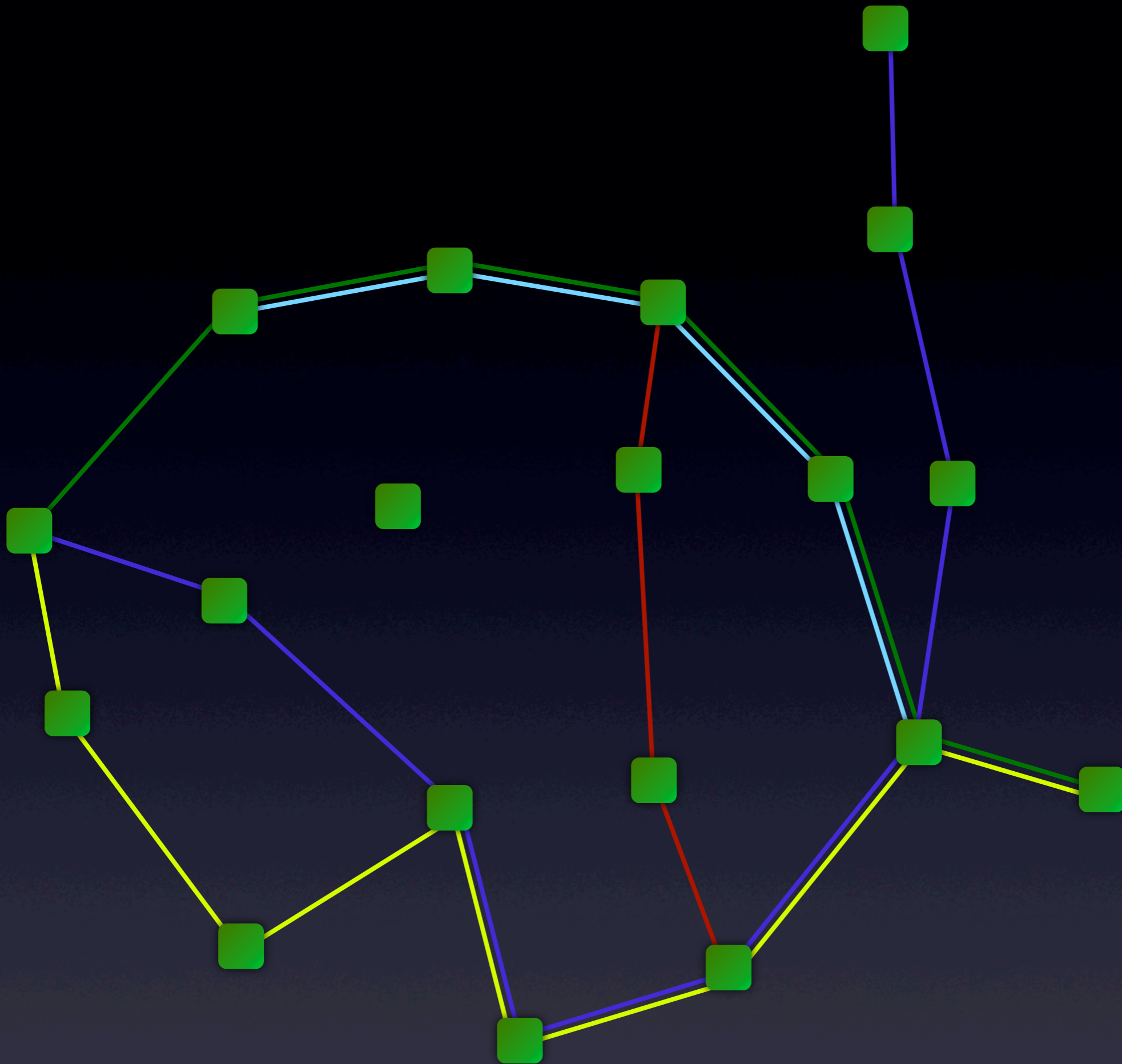

Stops

Lines

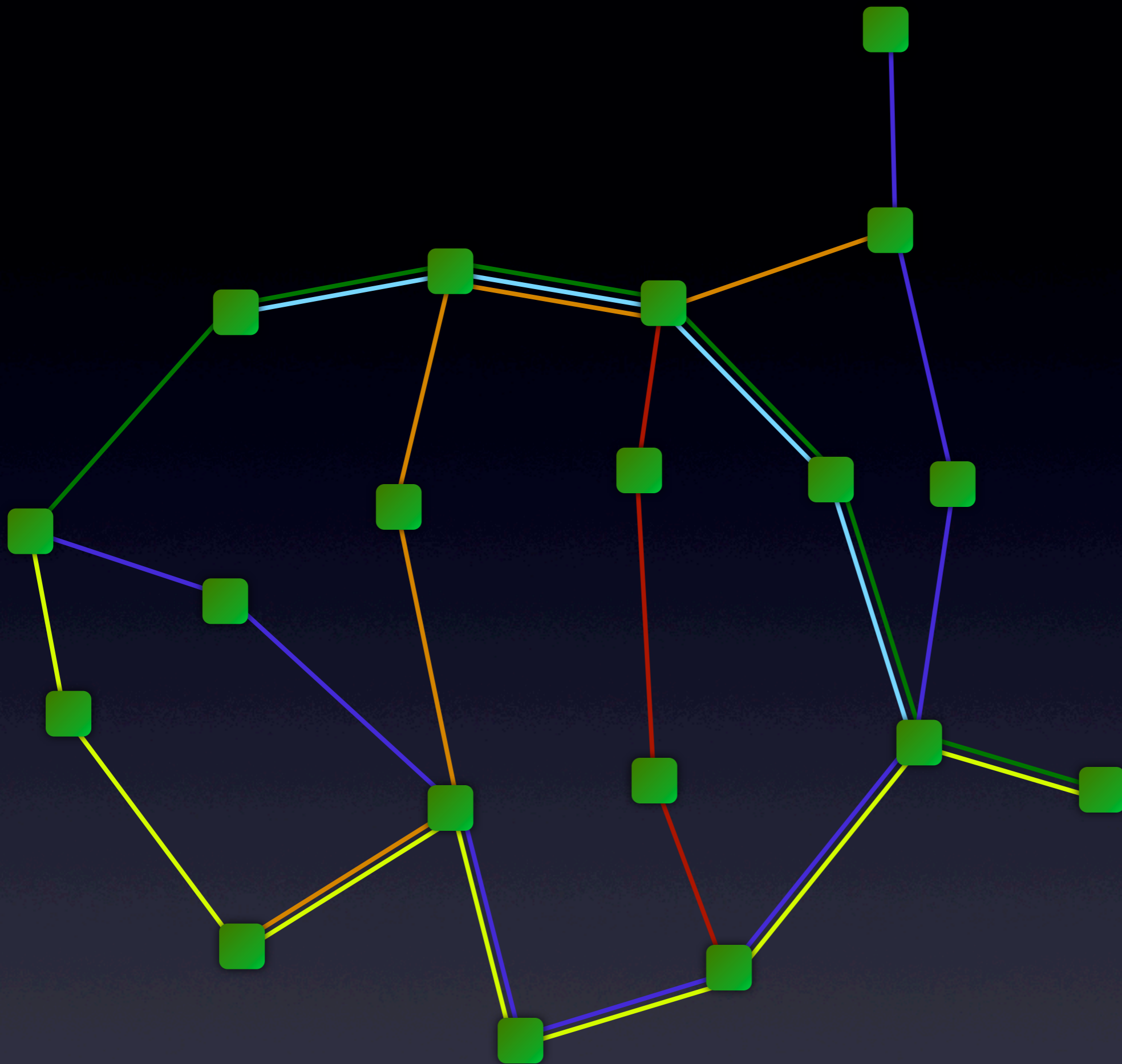

Stops

Lines

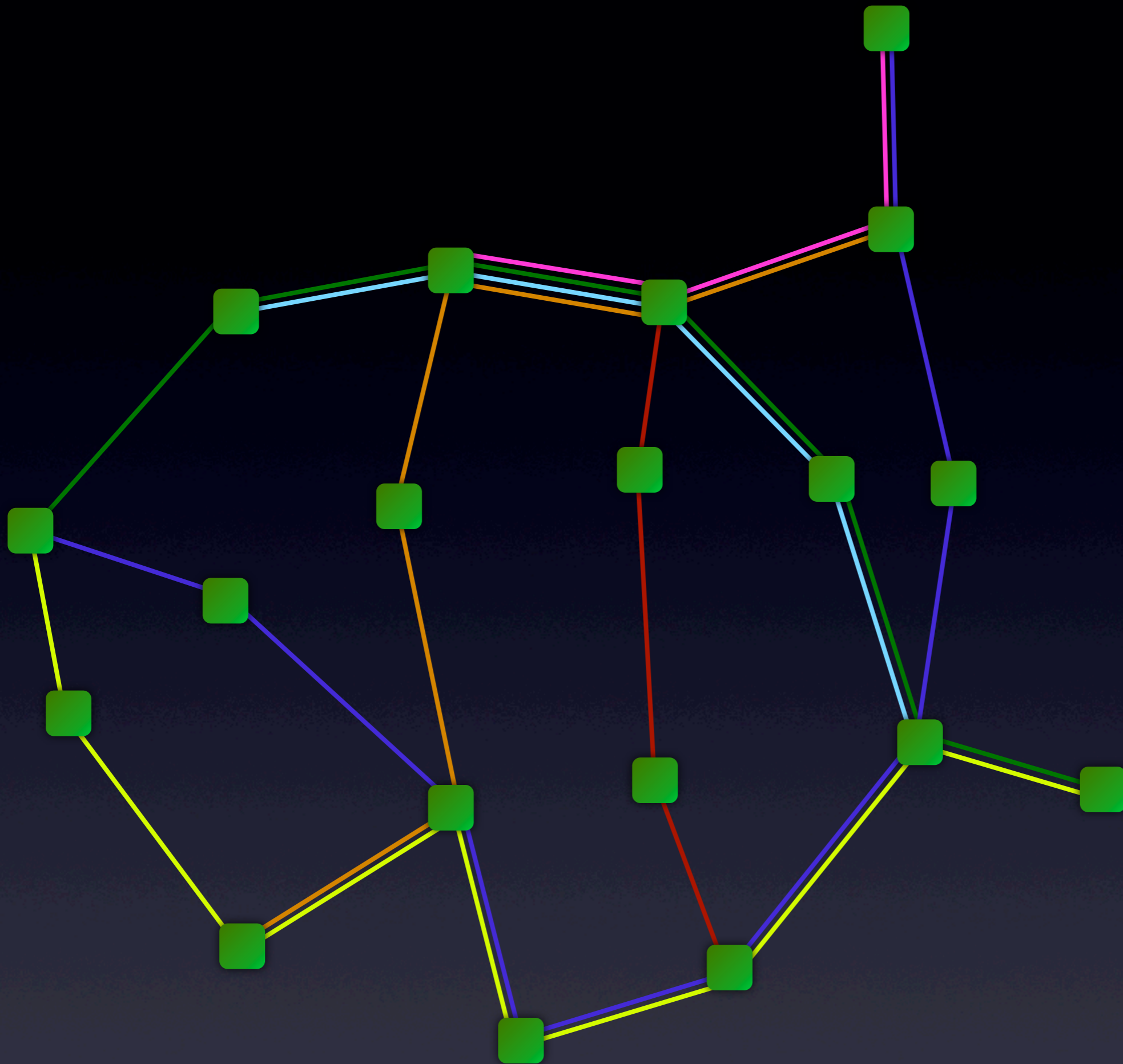

Stops

Lines

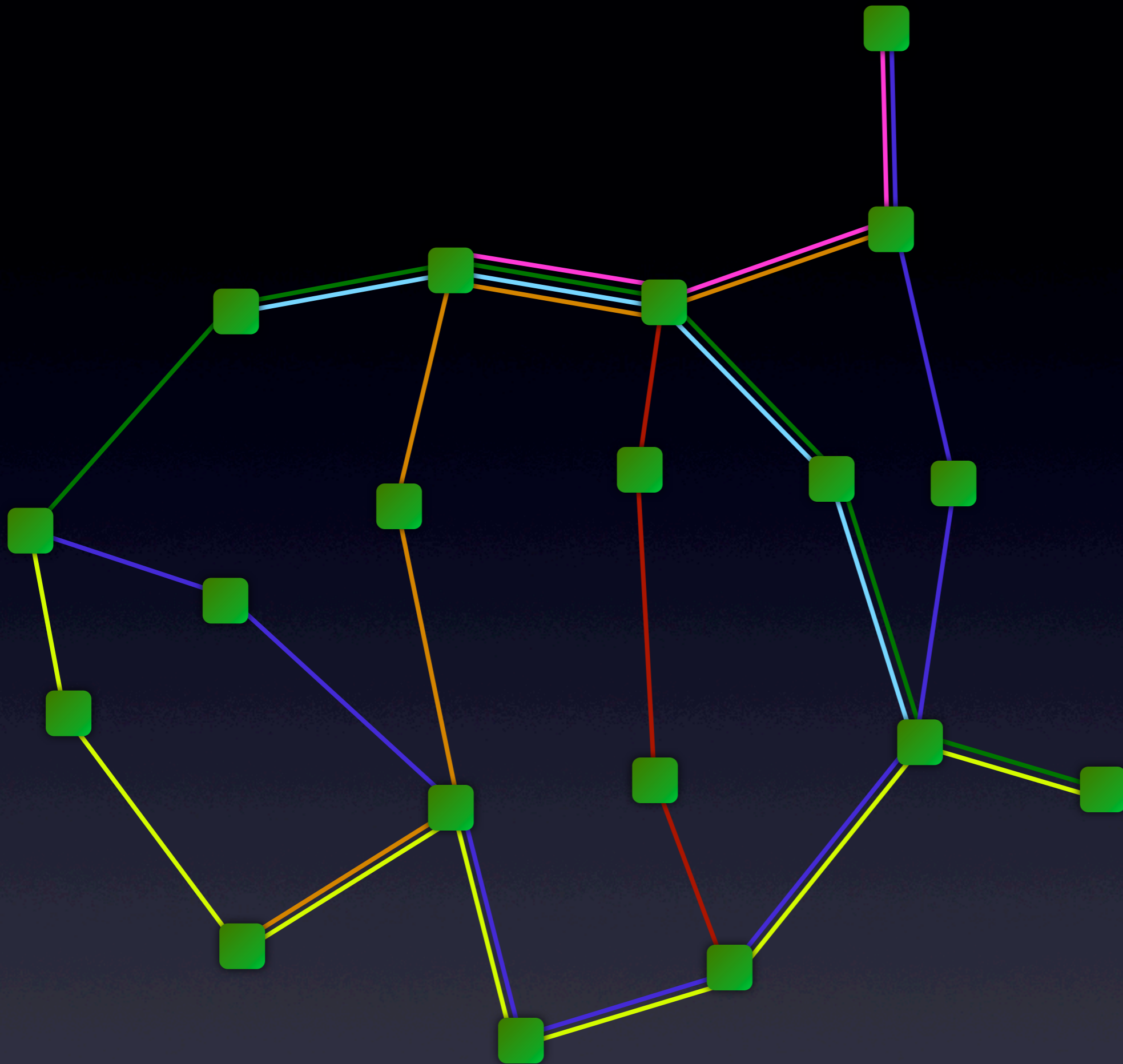

Stops

Lines

Timetable

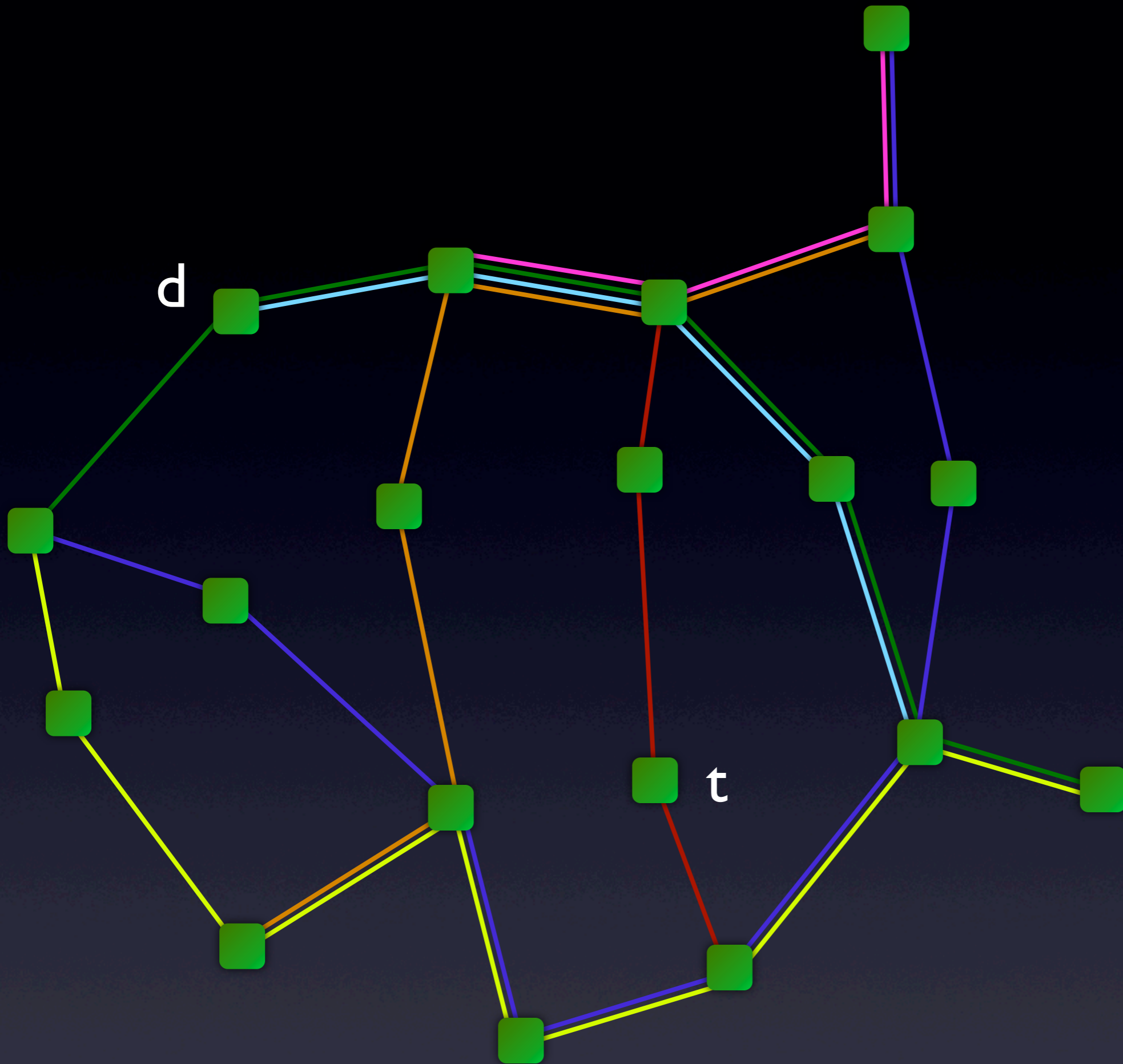

Stops

Lines

Timetable

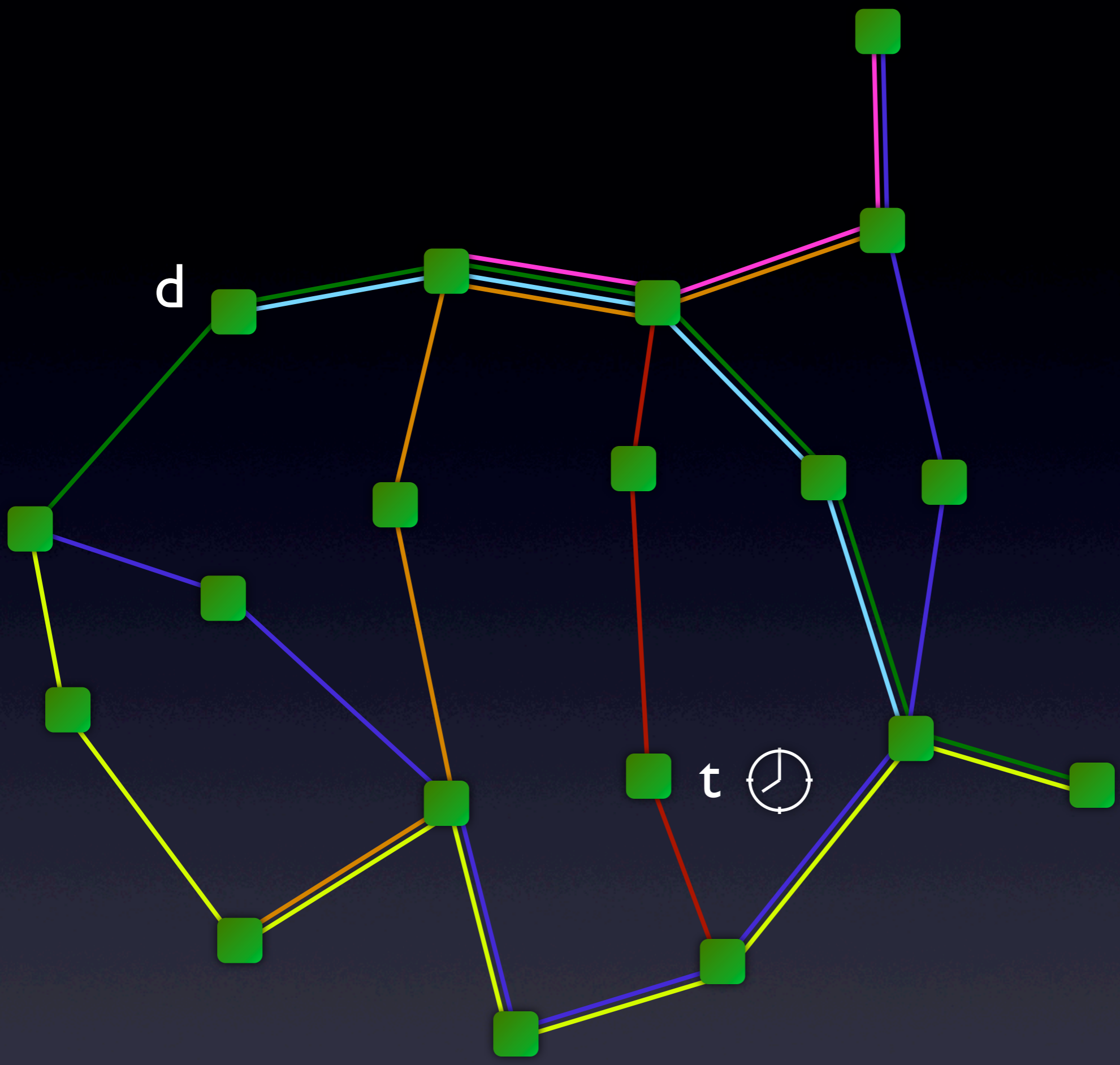

d

t



Stops

Lines

Timetable

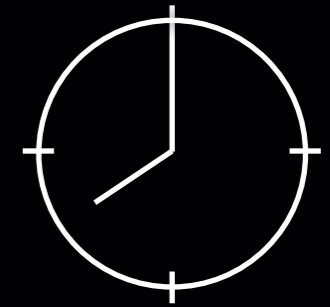

Home

ETH



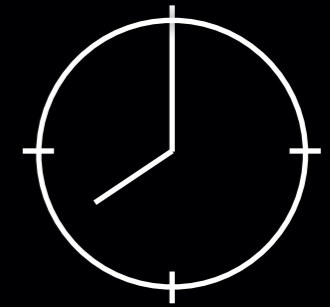

07:34	31
07:35	3
07:39	14
07:42	31
07:43	3

07:40	10
07:42	6
07:47	10
07:49	6
07:55	10

...

...

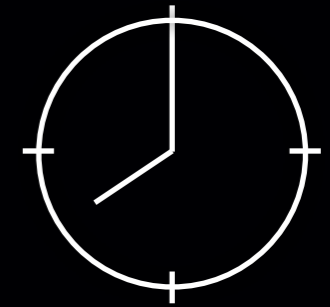

07:34	31
07:35	3
07:39	14
07:42	31
07:43	3

07:40	10
07:42	6
07:47	10
07:49	6
07:55	10

...

...

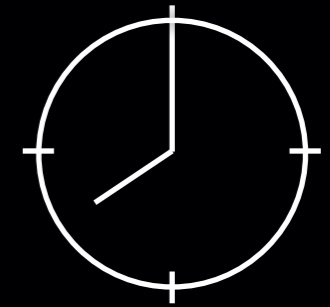

07:34	31
07:35	3
07:39	14
07:42	31
07:43	3
...	

07:42	10
07:44	6
07:48	10
07:54	6
07:59	10
...	

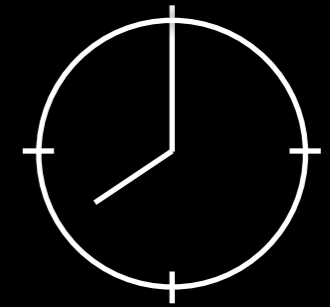

07:34	31
07:35	3
07:39	14
07:42	31
07:43	3

07:42	10
07:44	6
07:48	10
07:54	6
07:59	10

...

...

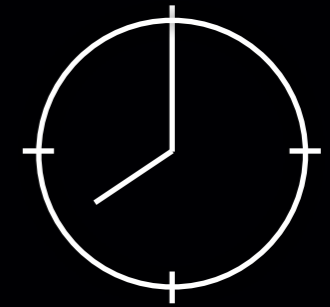

07:34	31
07:35	3
07:39	14
07:42	31
07:43	3
...	

07:42	10
07:44	6
07:48	10
07:54	6
07:59	10
...	

# Planned vs. Real Travel Time

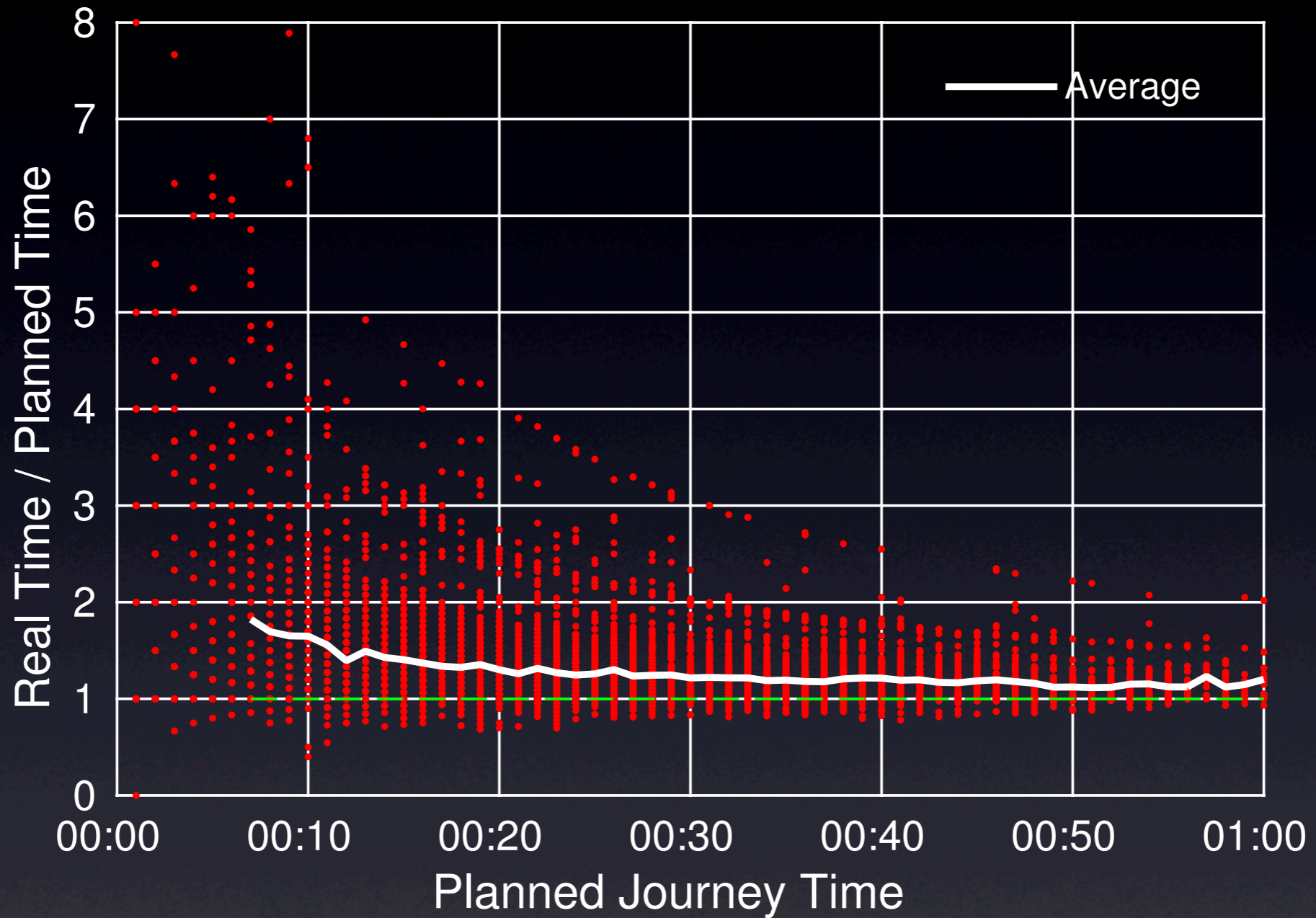

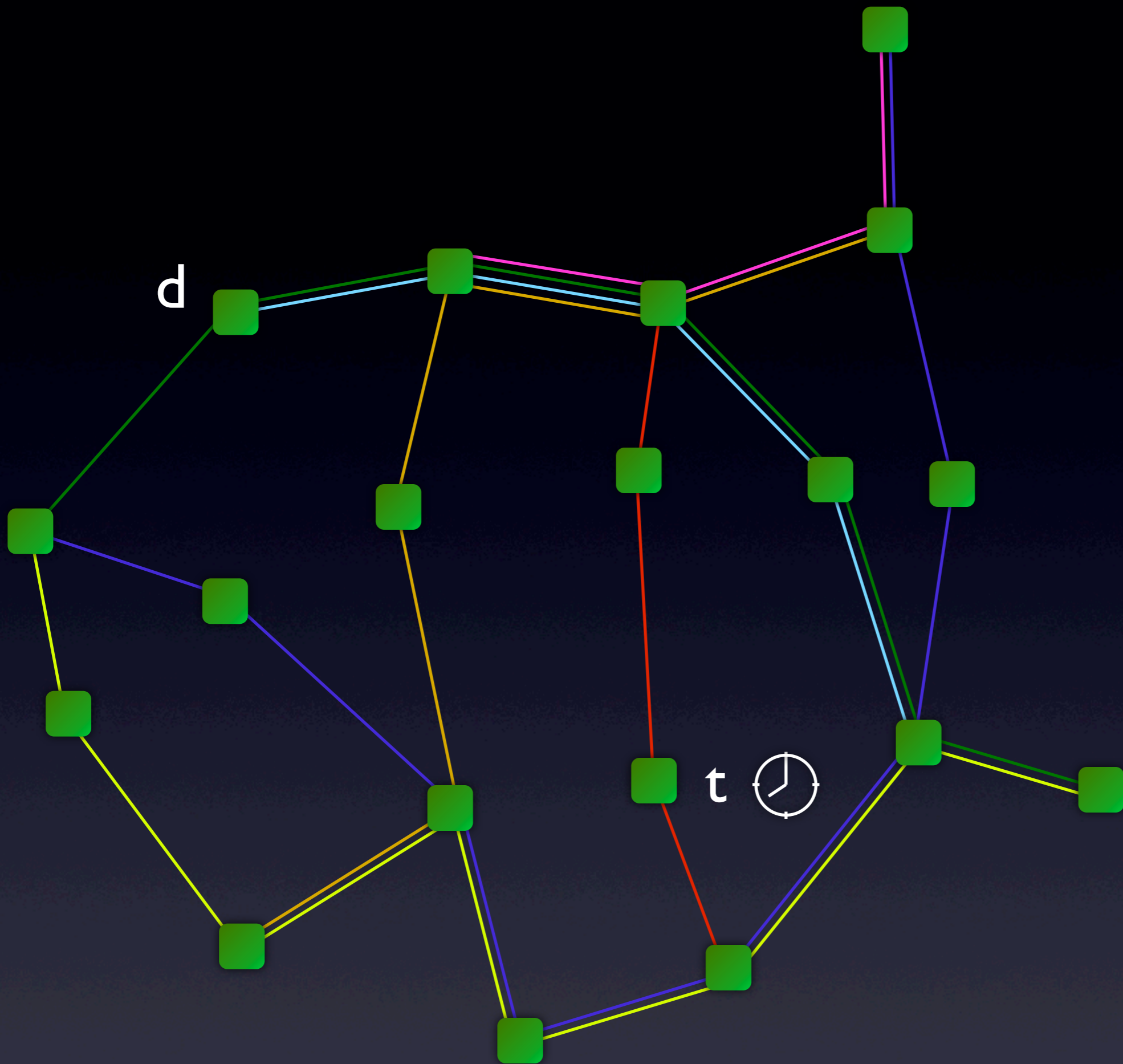

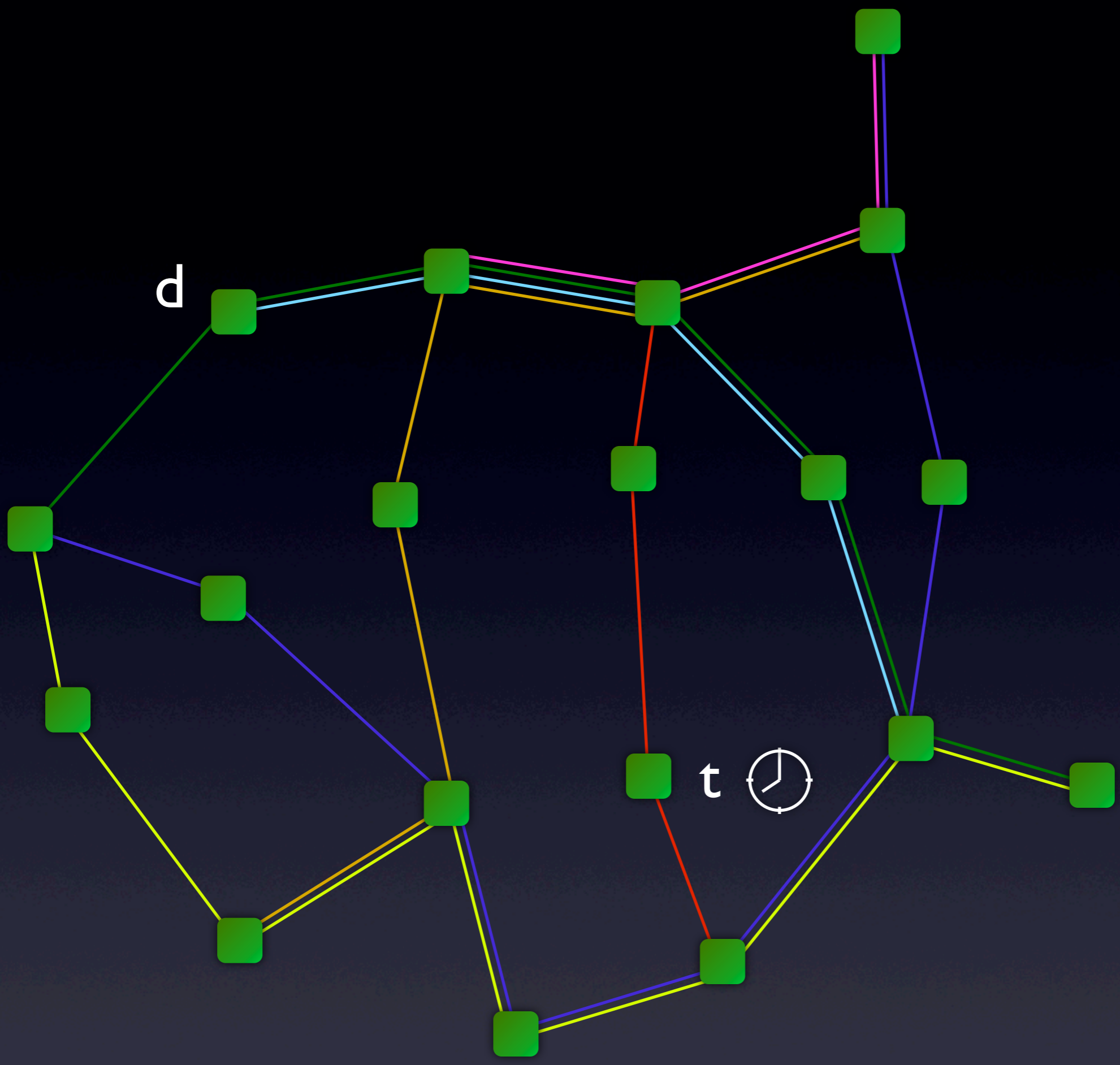

Stops

Lines

Timetable



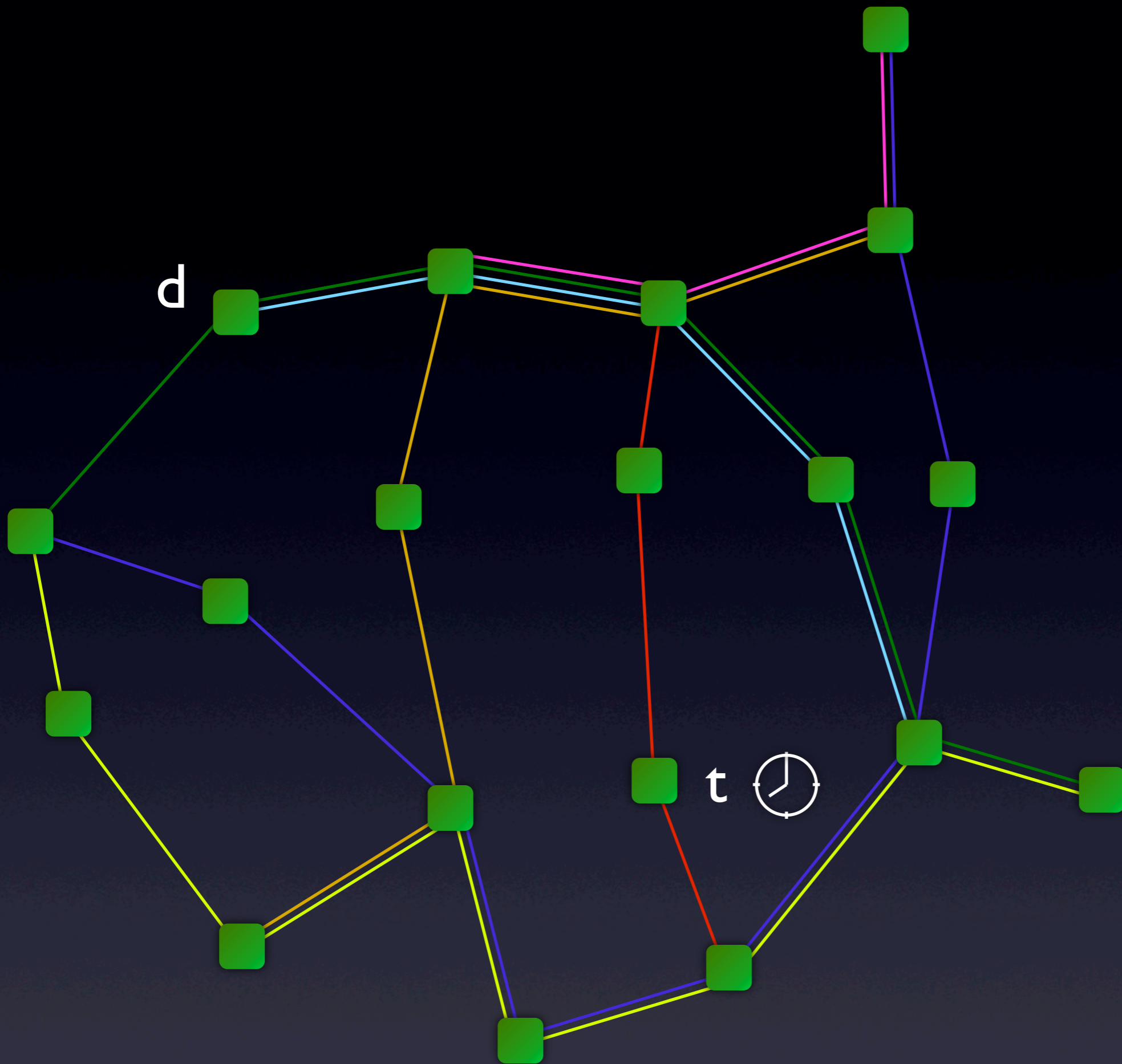

Stops

Lines

Timetable

Recorded  
timetables

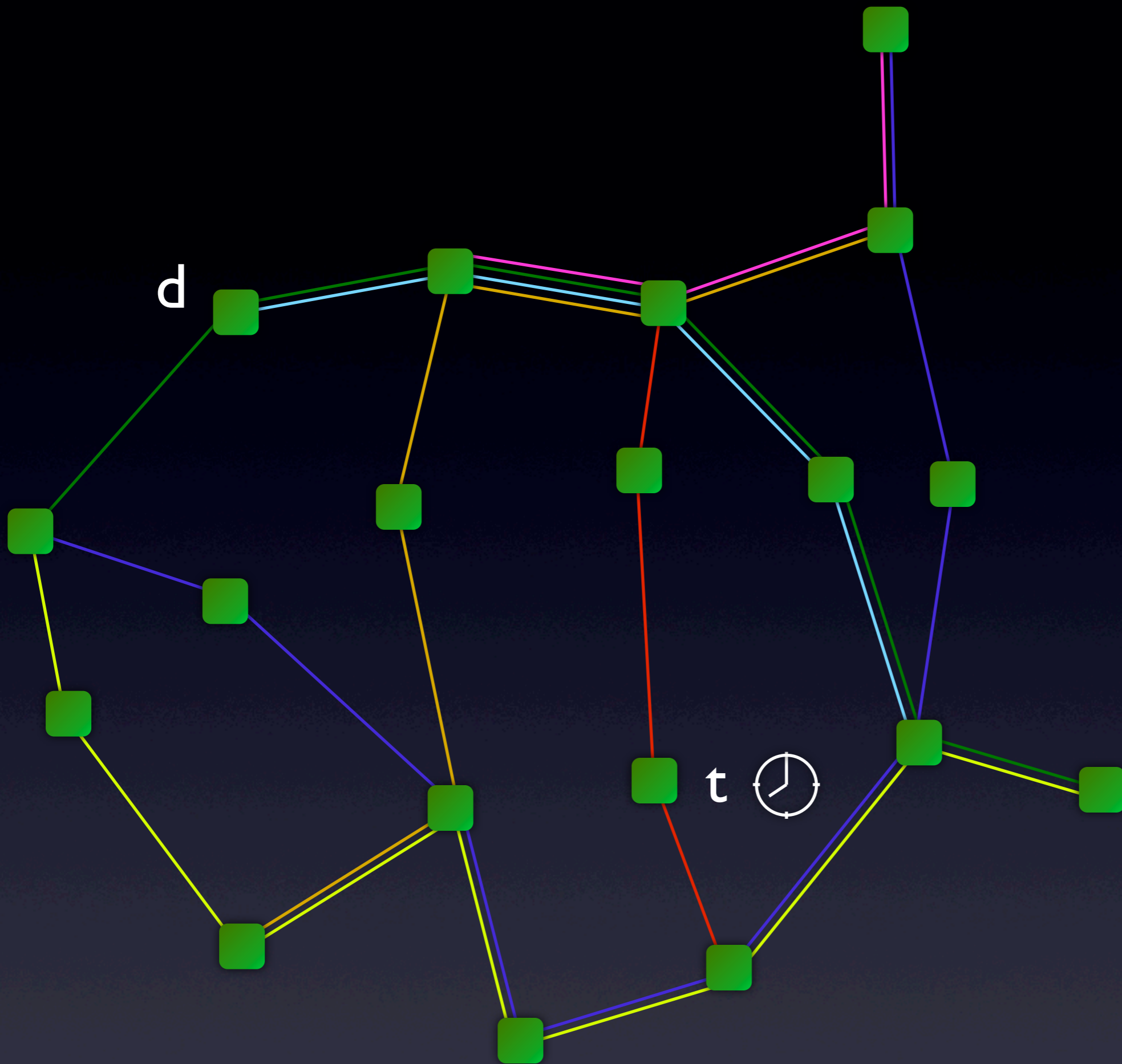

Stops

Lines

Timetable

Recorded  
timetables

Solutions?

07:43	from	Zürich, Sihlpost/HB
	3	Direction: Zürich, Klusplatz
07:47 07:49	to from	Zürich HB
	6	Direction: Zürich, Zoo
07:56	to	Zürich, ETH/Universitätsspital

Zürich, Sihlpost/HB

3

Zürich HB

6

Zürich, ETH/Universitätsspital

3

Zürich HB

6

3

6





3

6



Tuesday

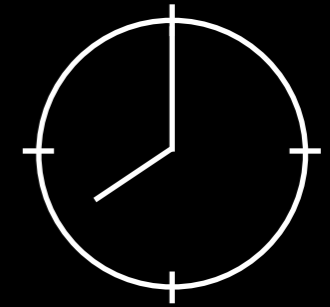

21 Minutes



16 Minutes

Wednesday

Tuesday

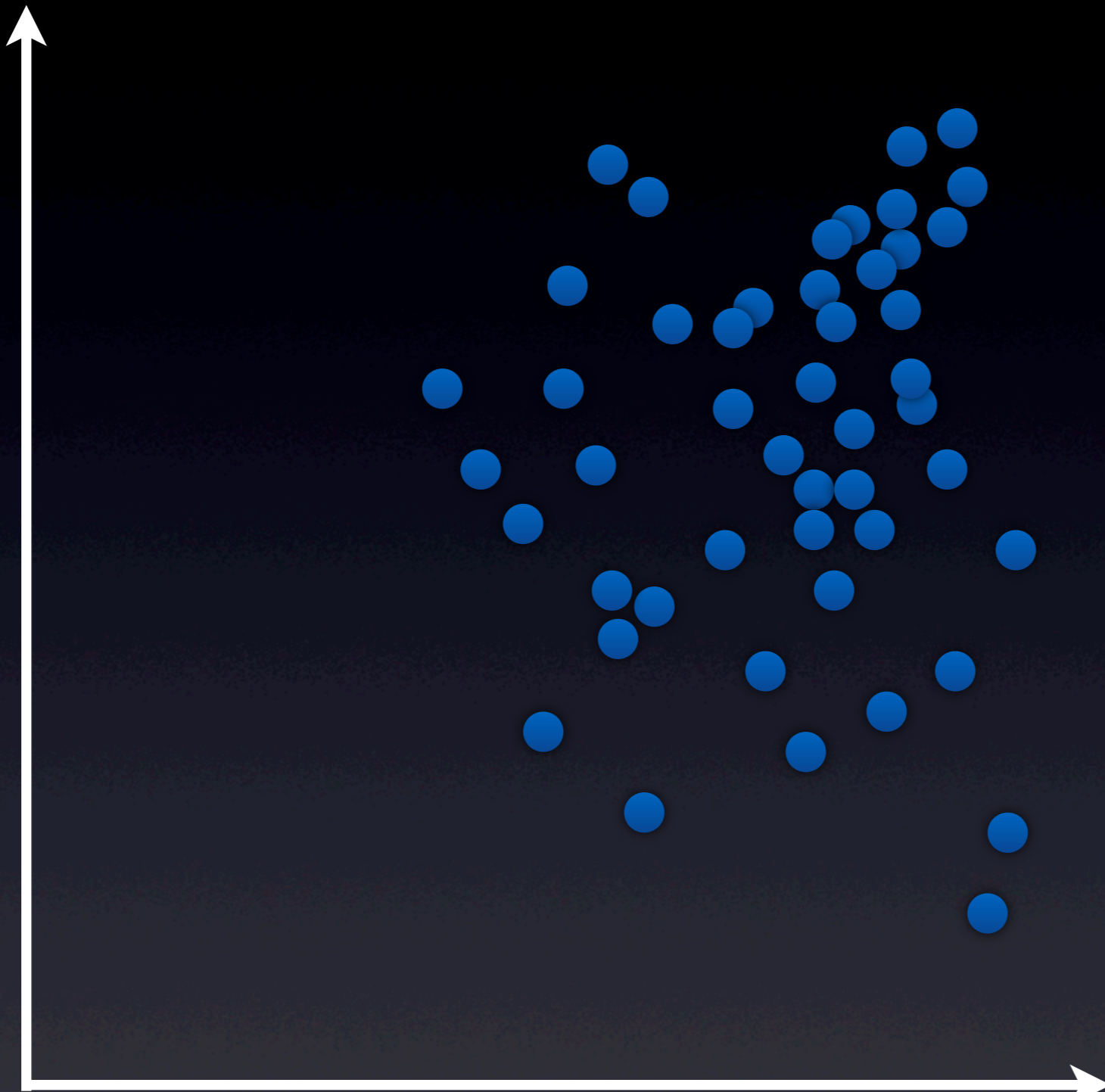
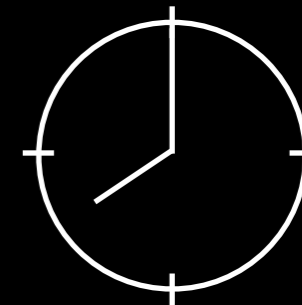

Wednesday

Tuesday

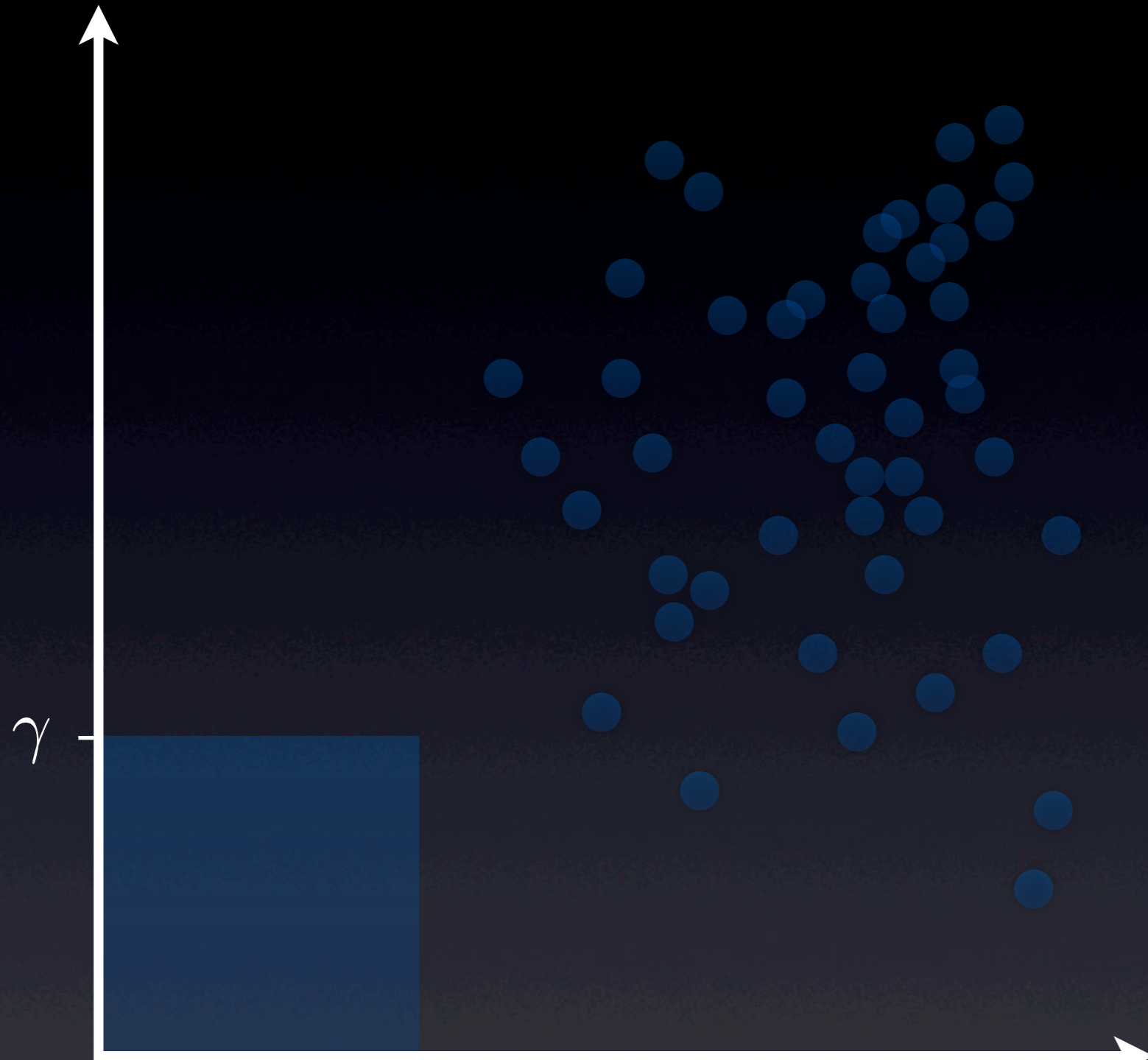
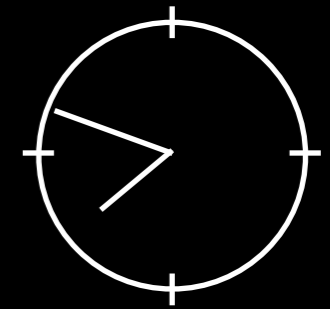

Wednesday

Tuesday

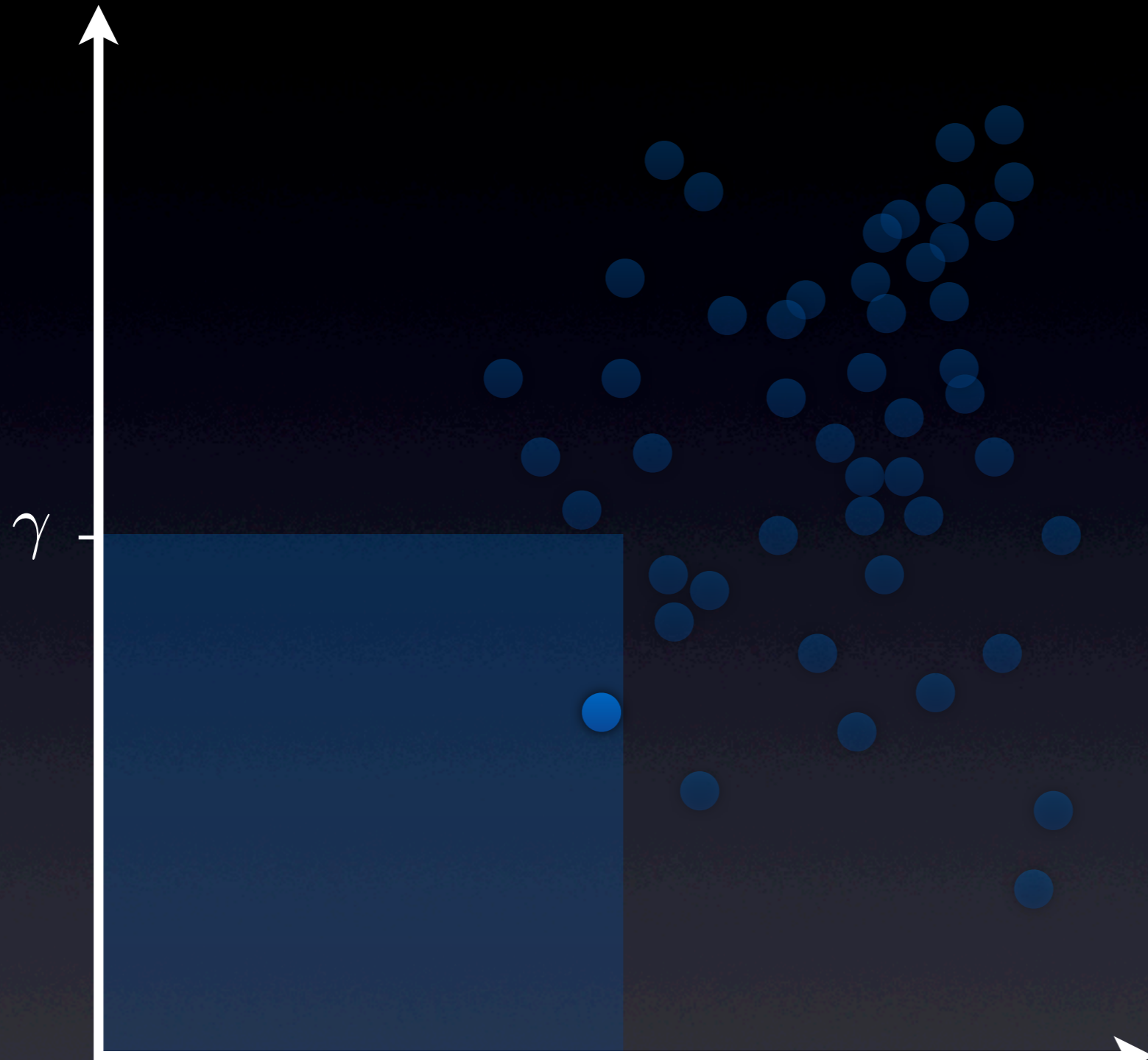
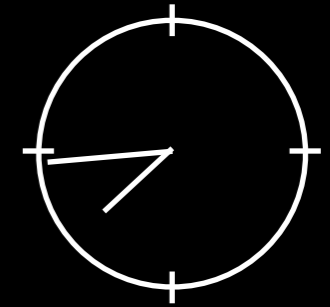

Wednesday

$\gamma$

$\gamma$

Tuesday

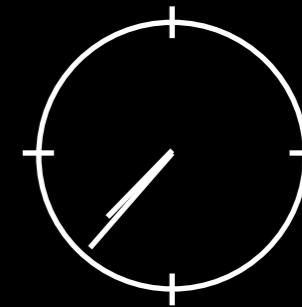

$\gamma$

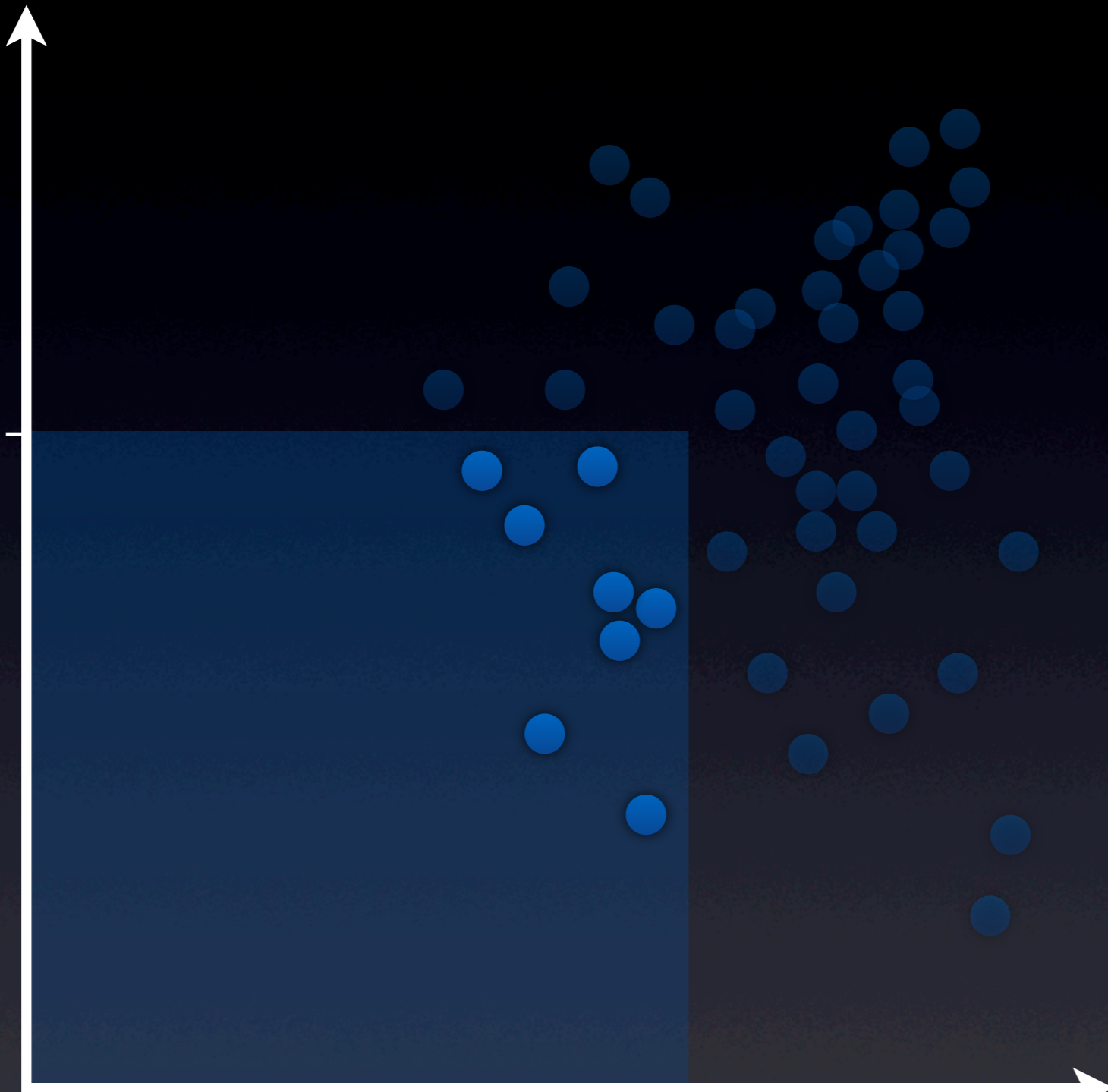

$\gamma$

Wednesday

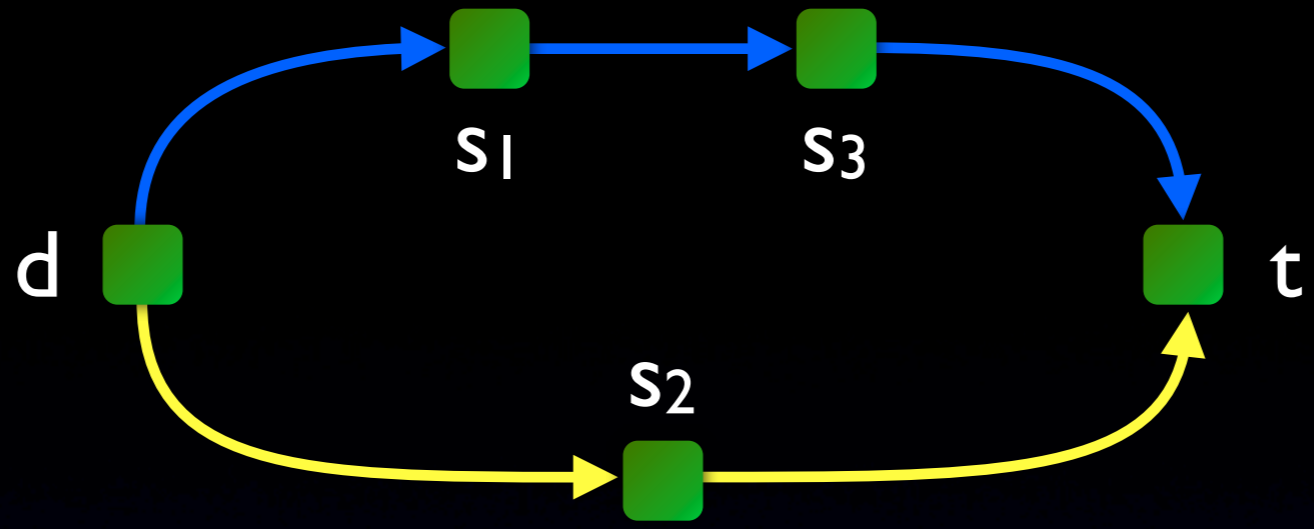

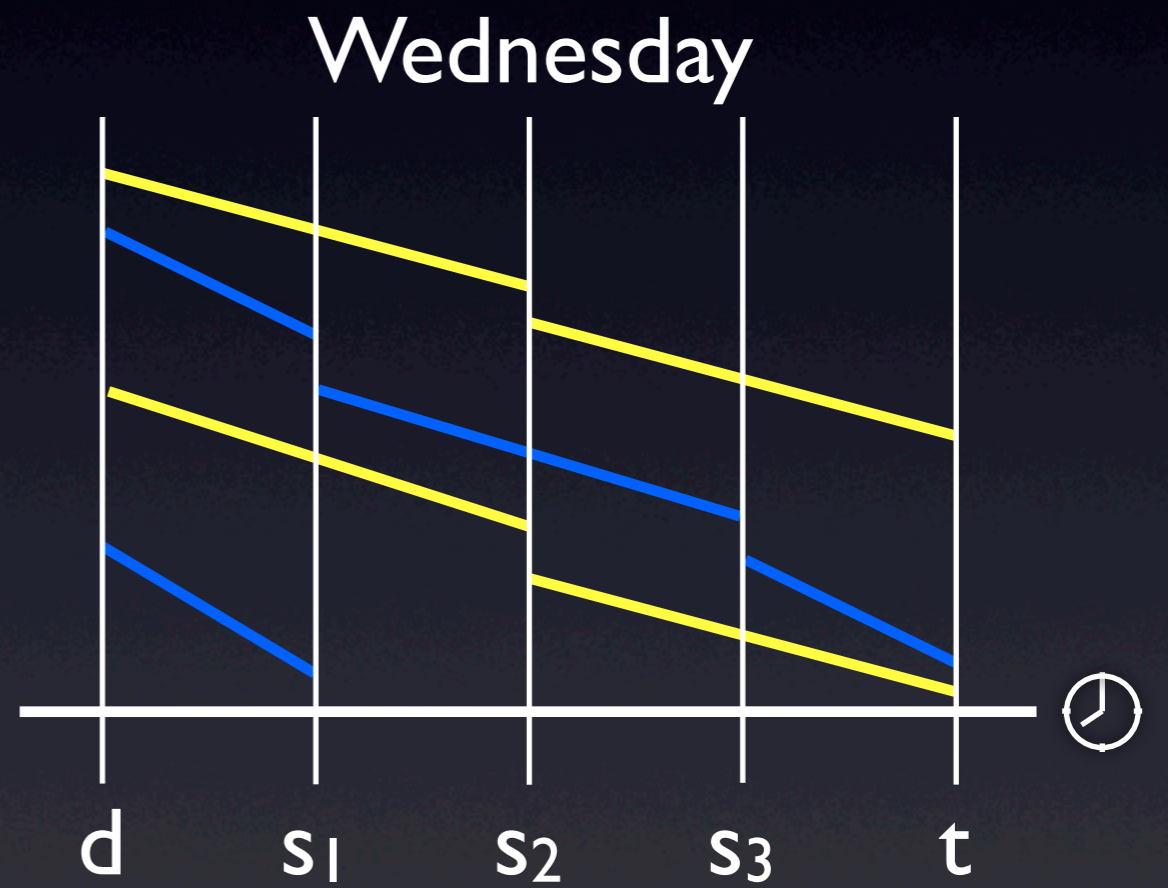
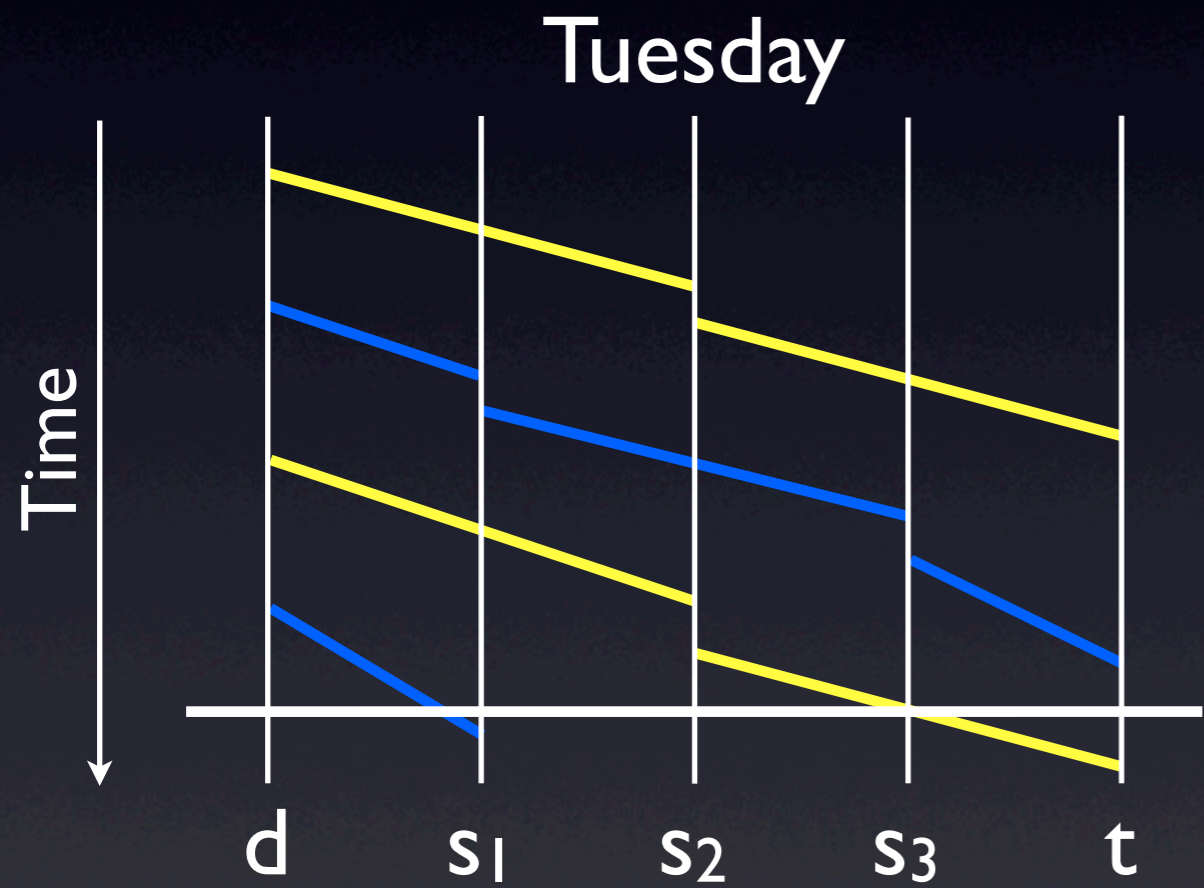
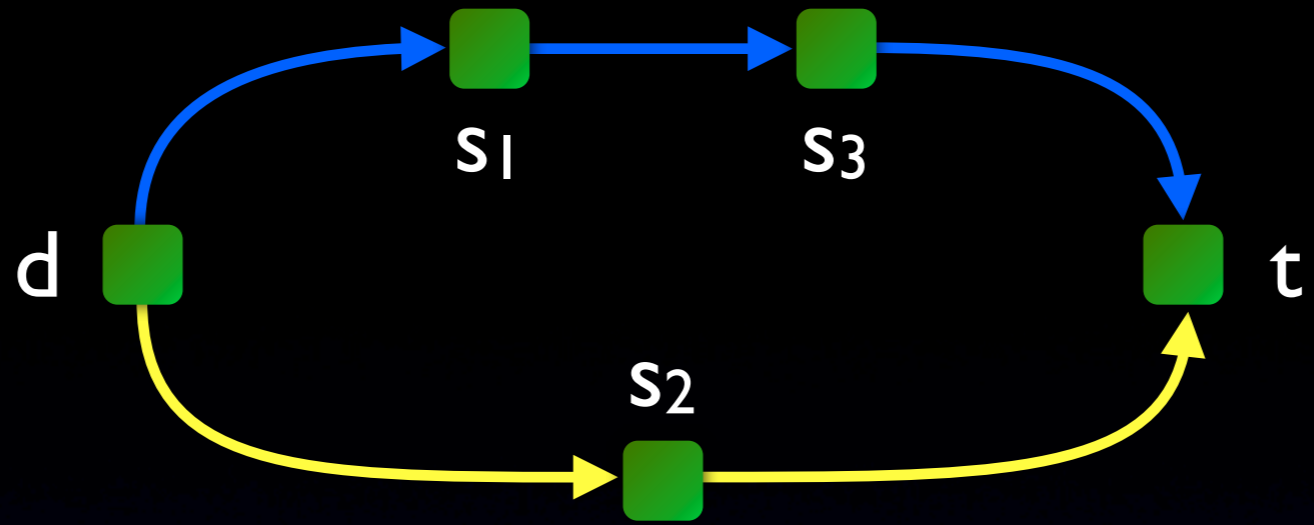

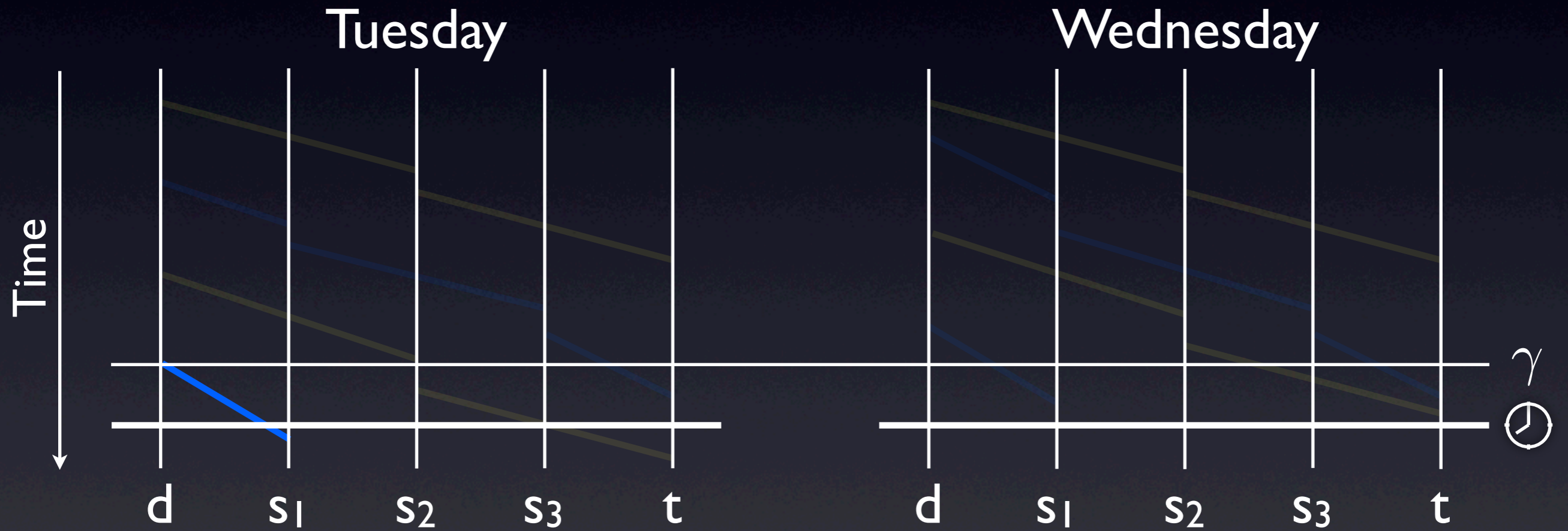
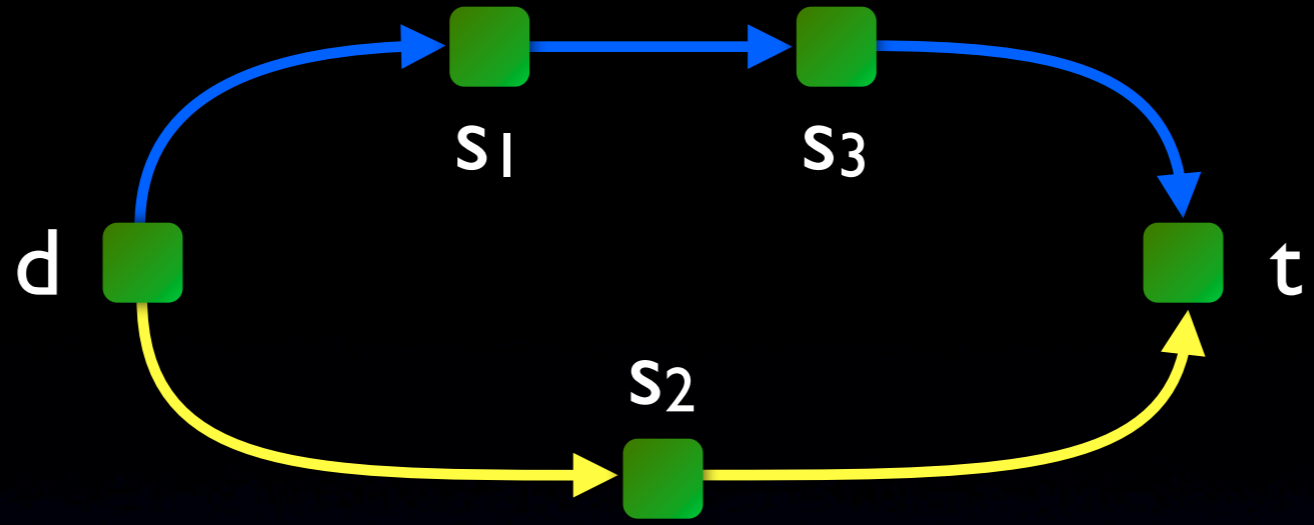



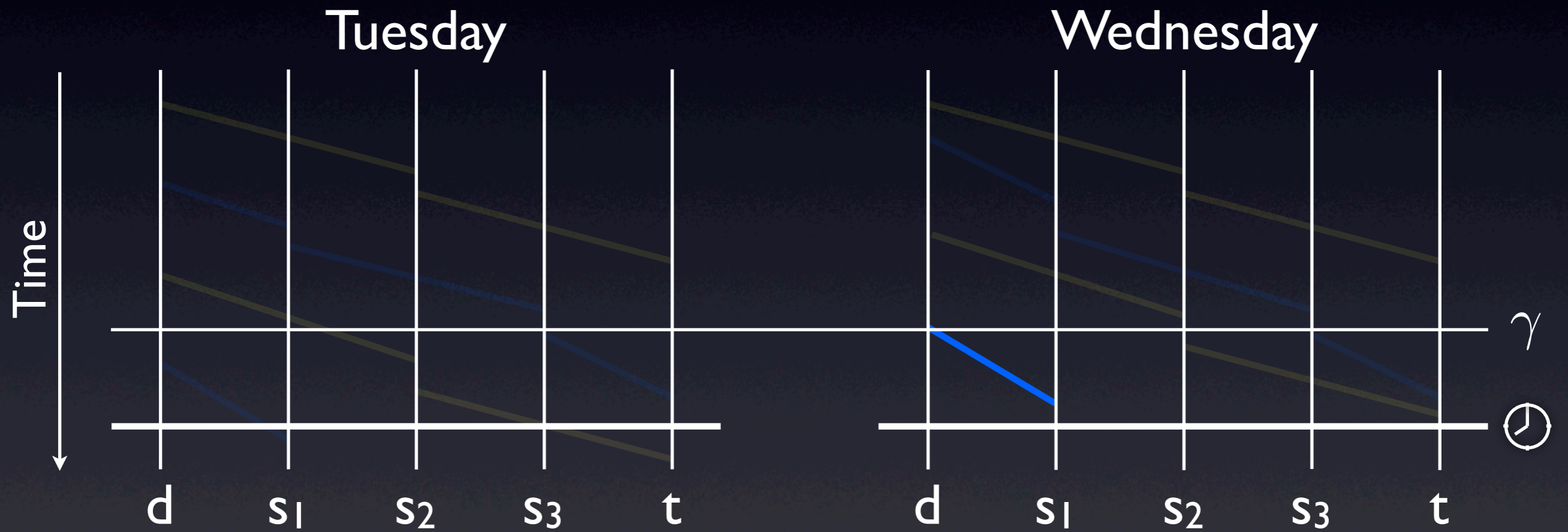
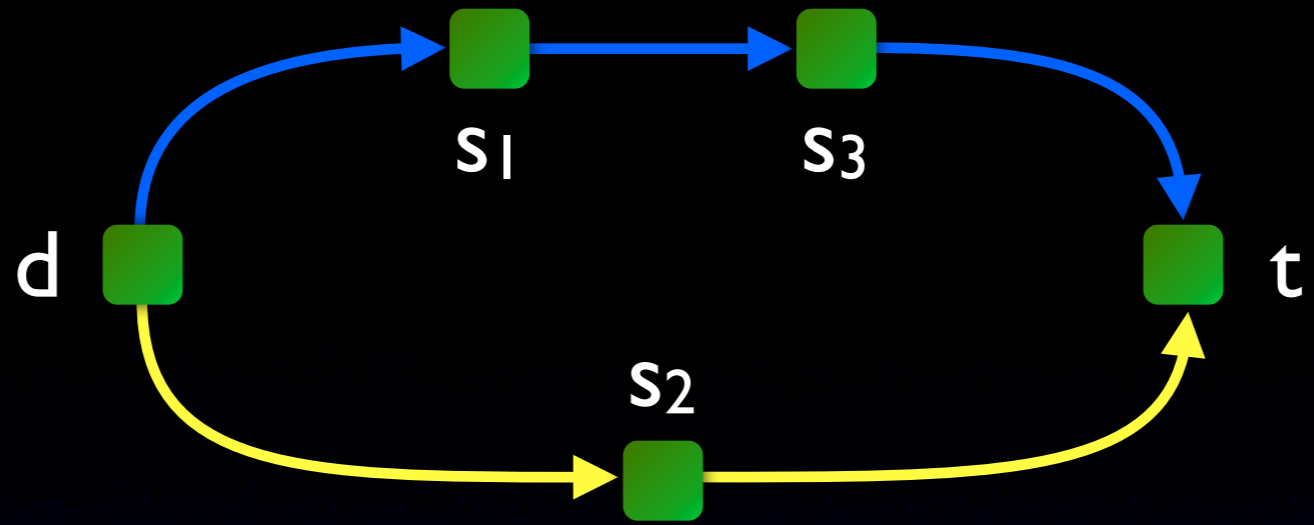

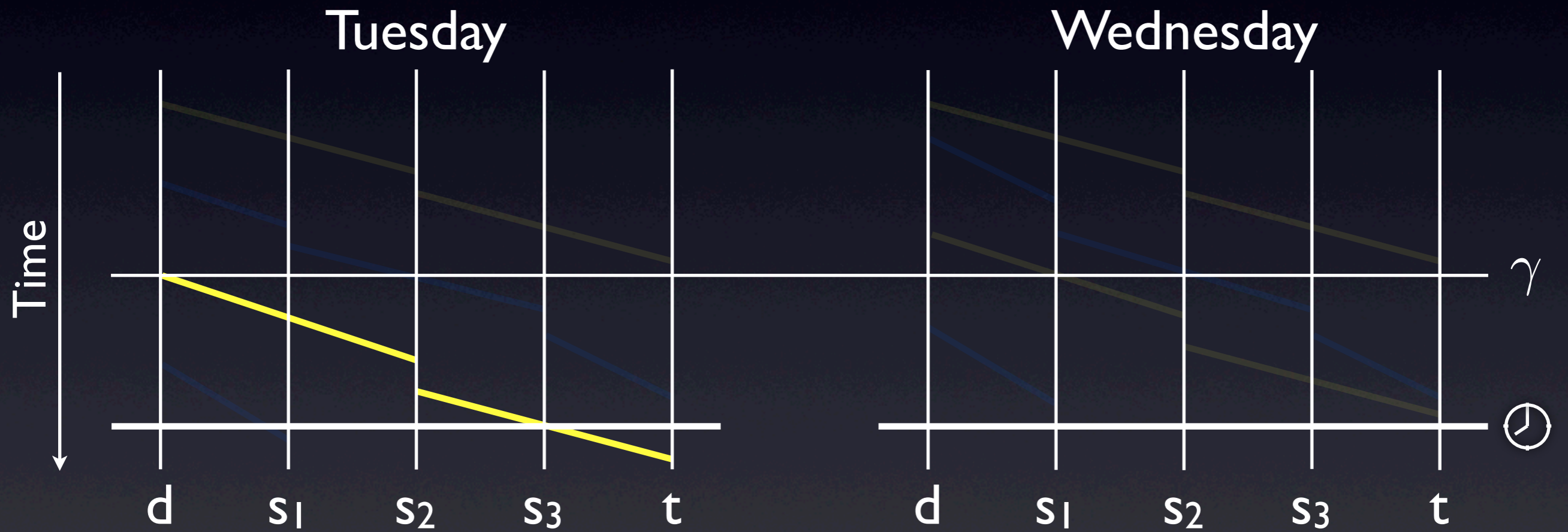
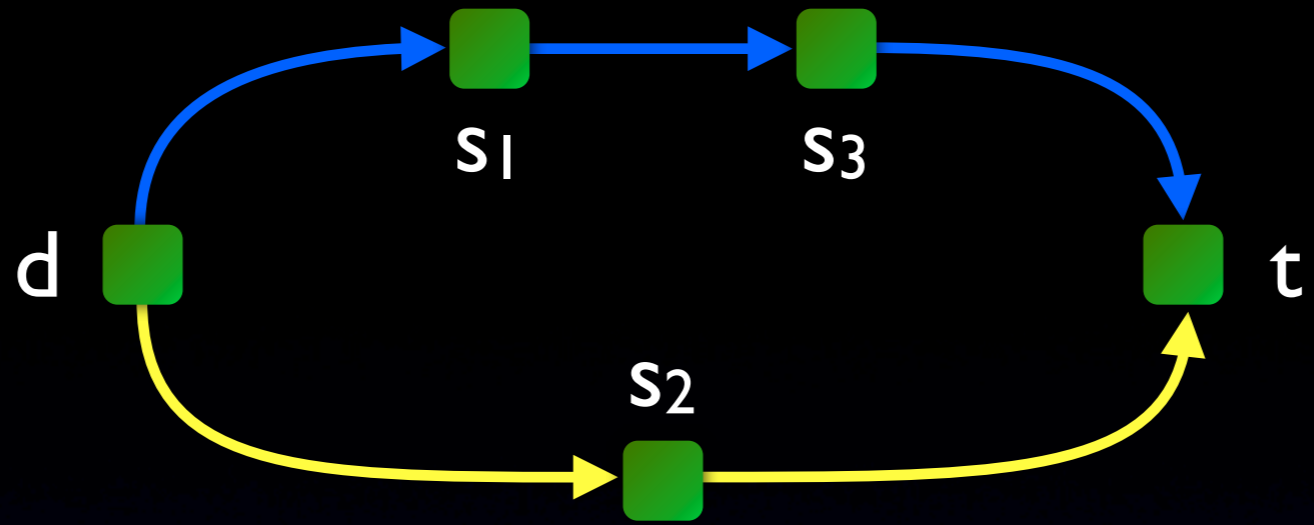

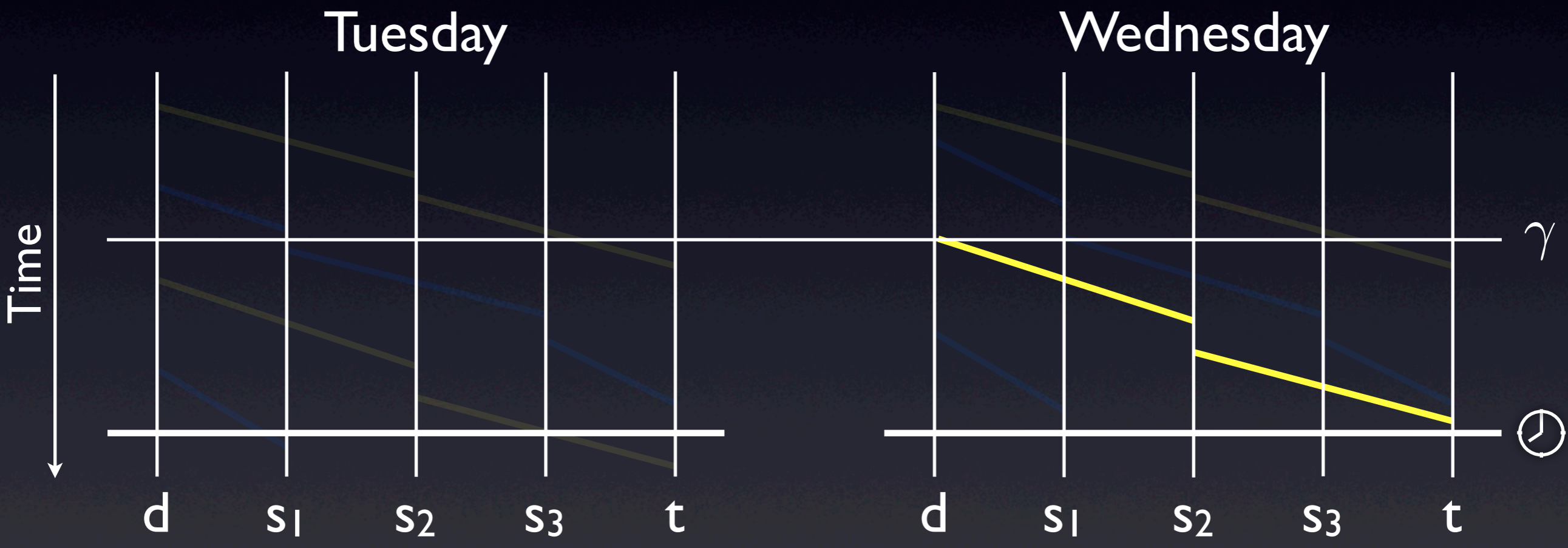
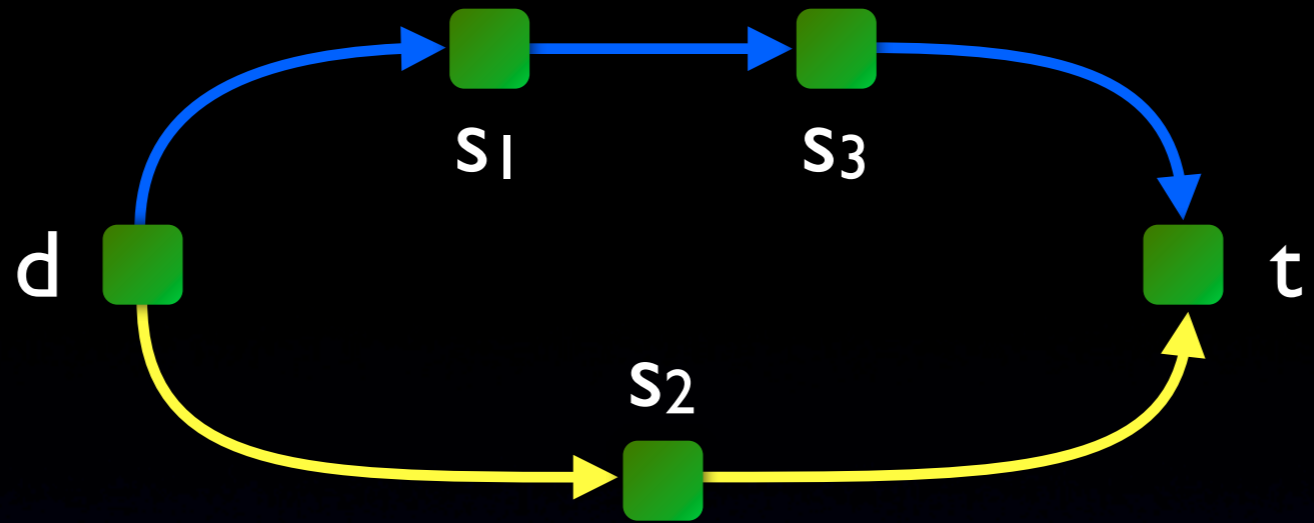

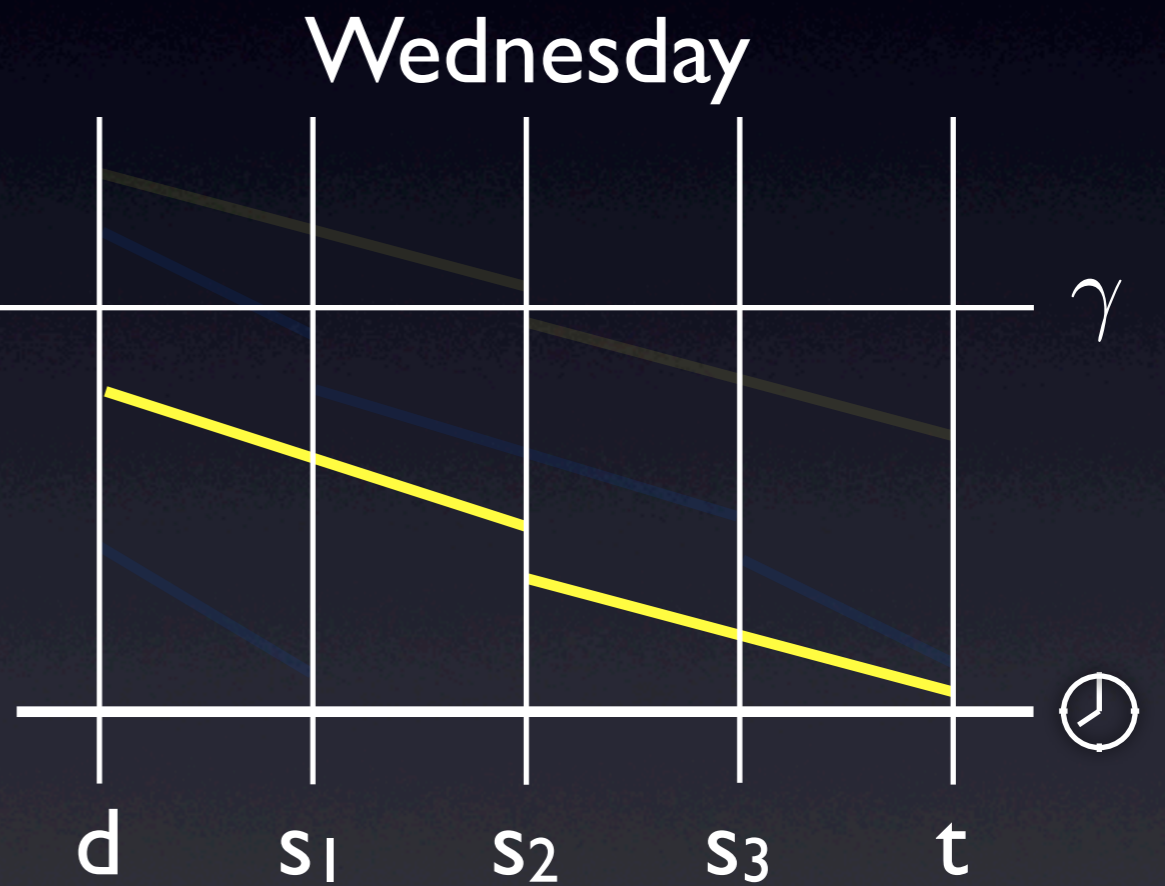
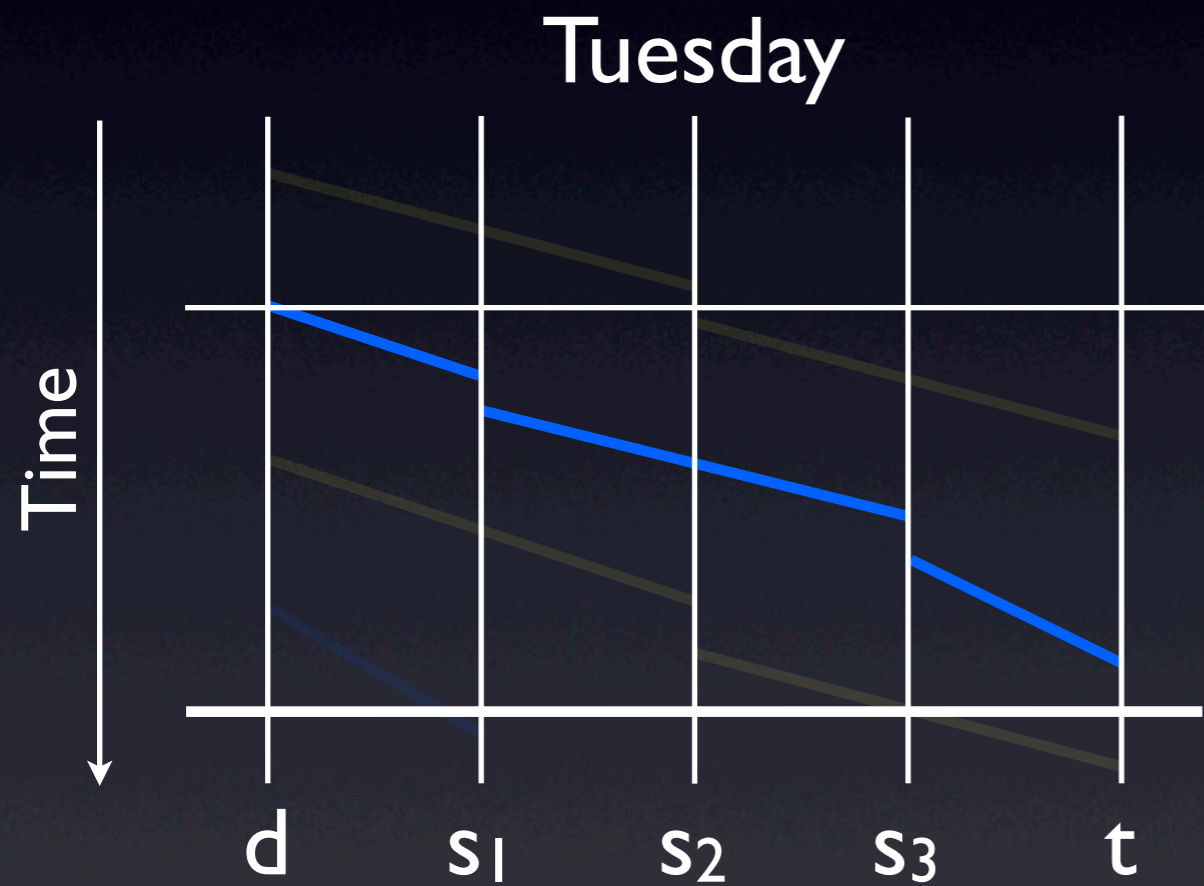
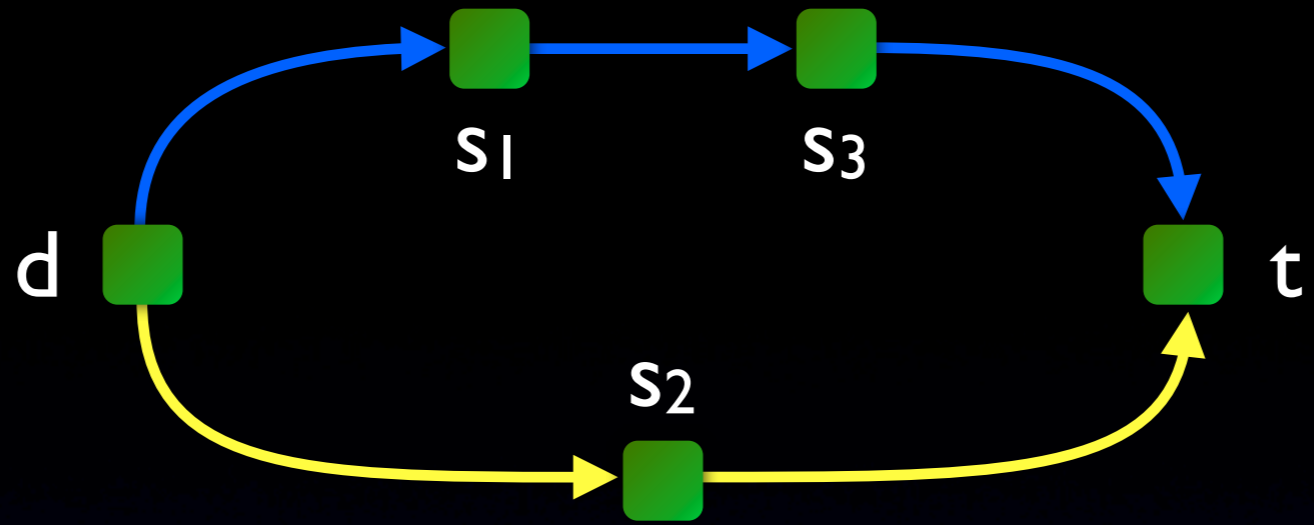

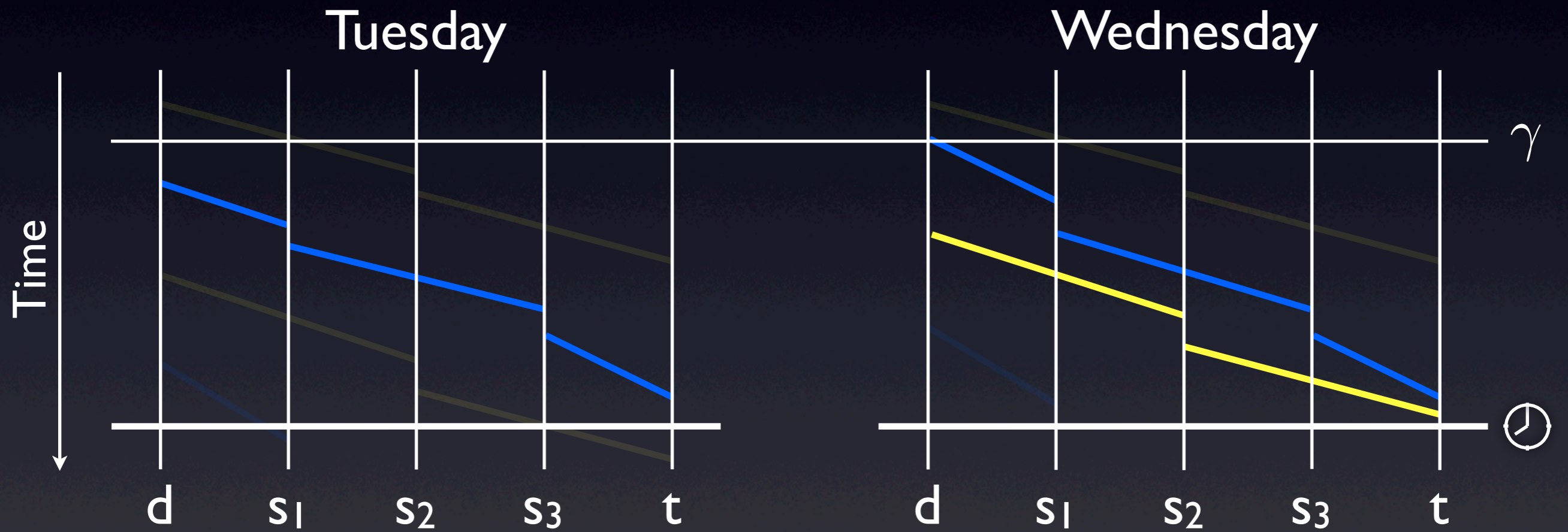
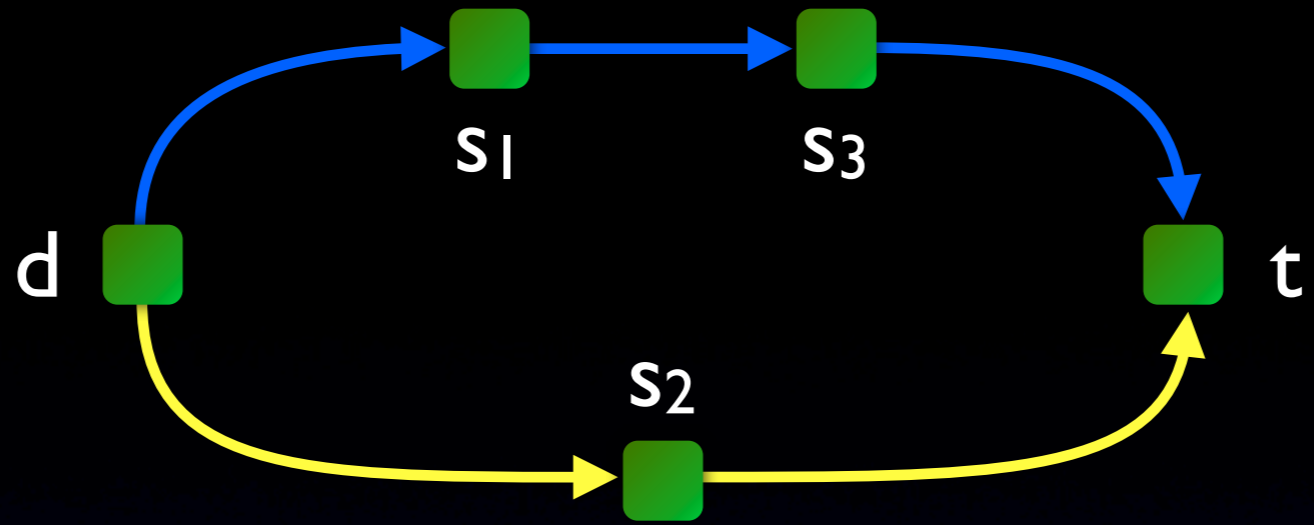

# Arrival Rates

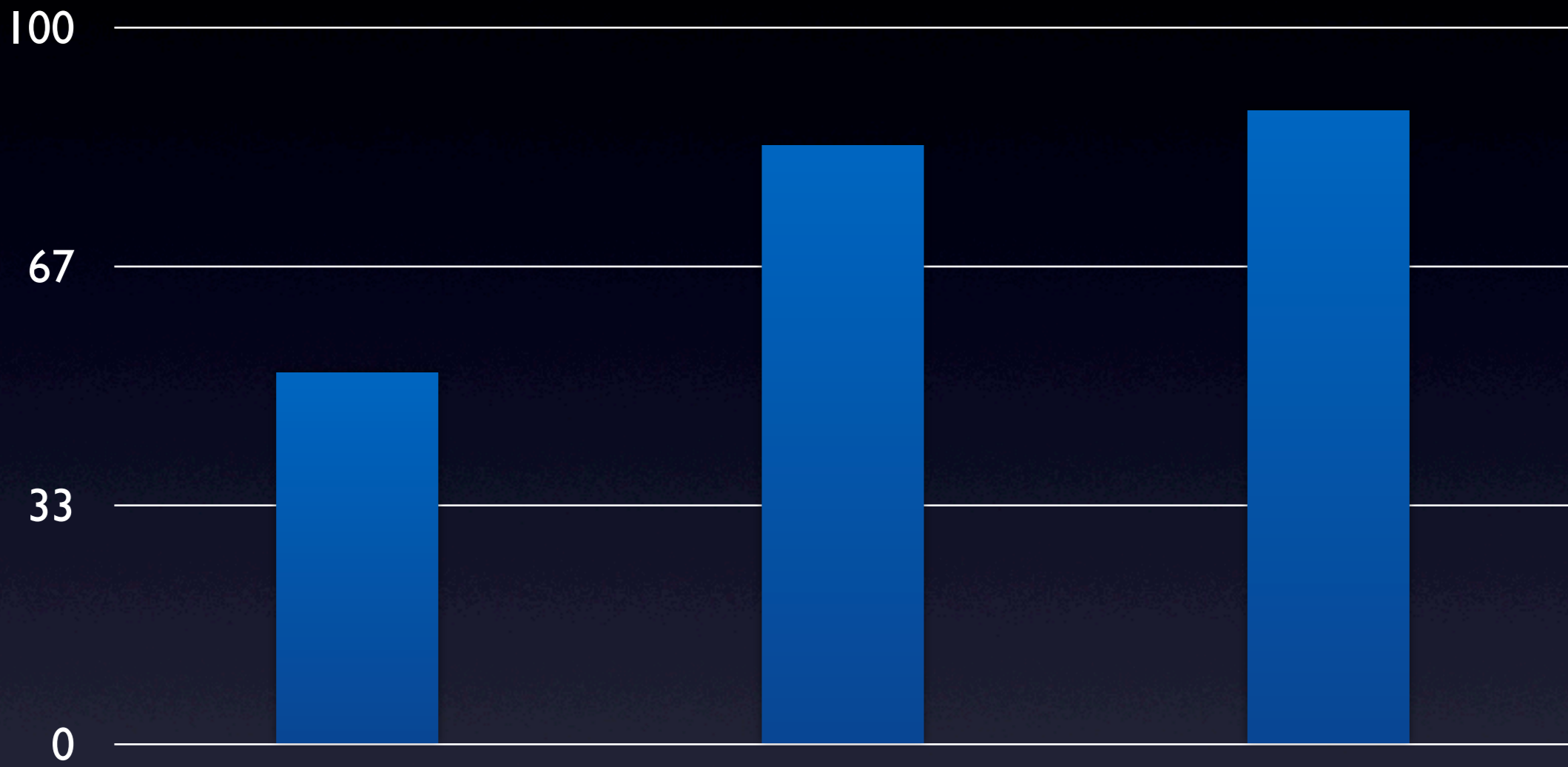

# Arrival Rates

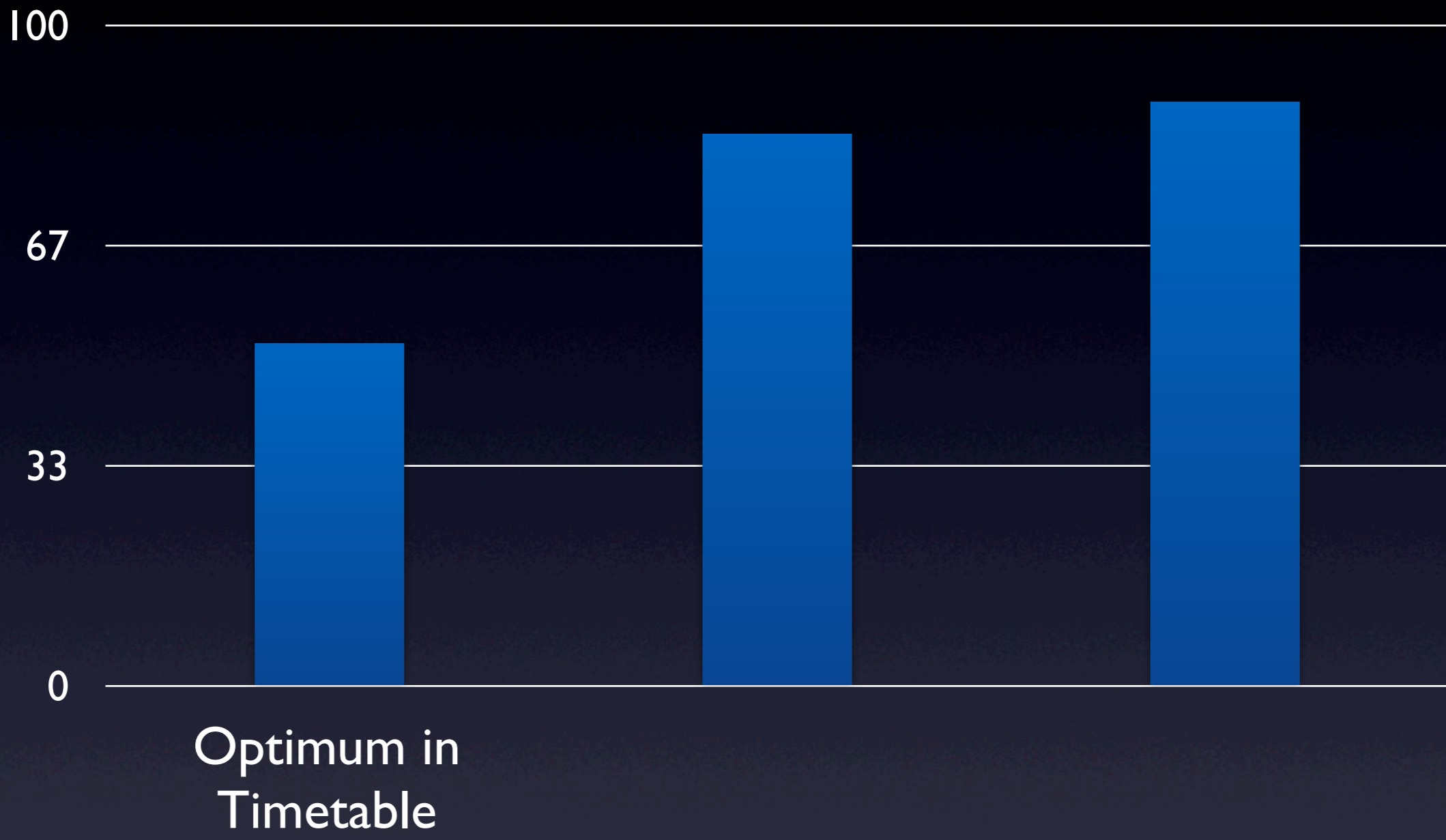

# Arrival Rates

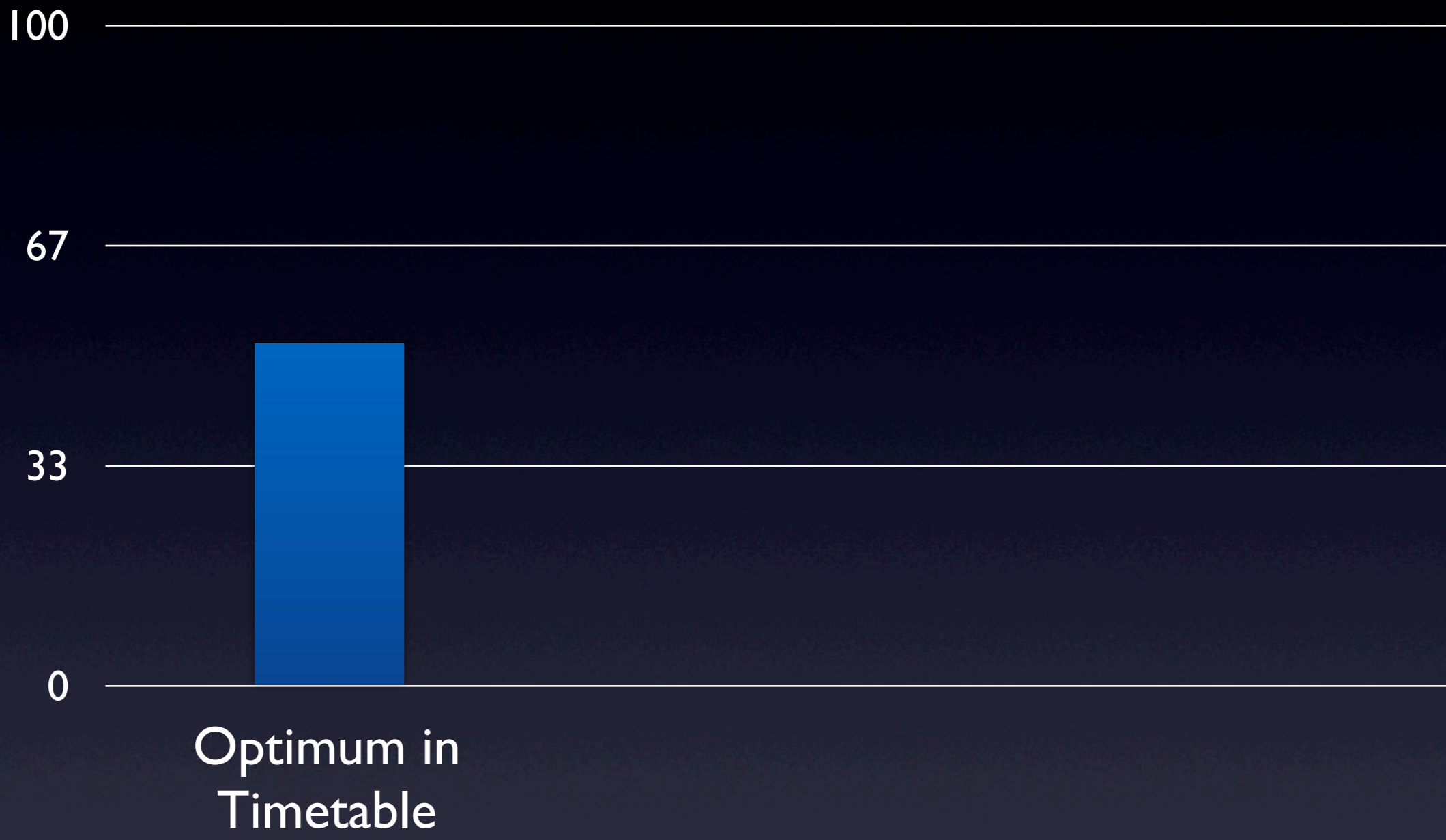



# Arrival Rates

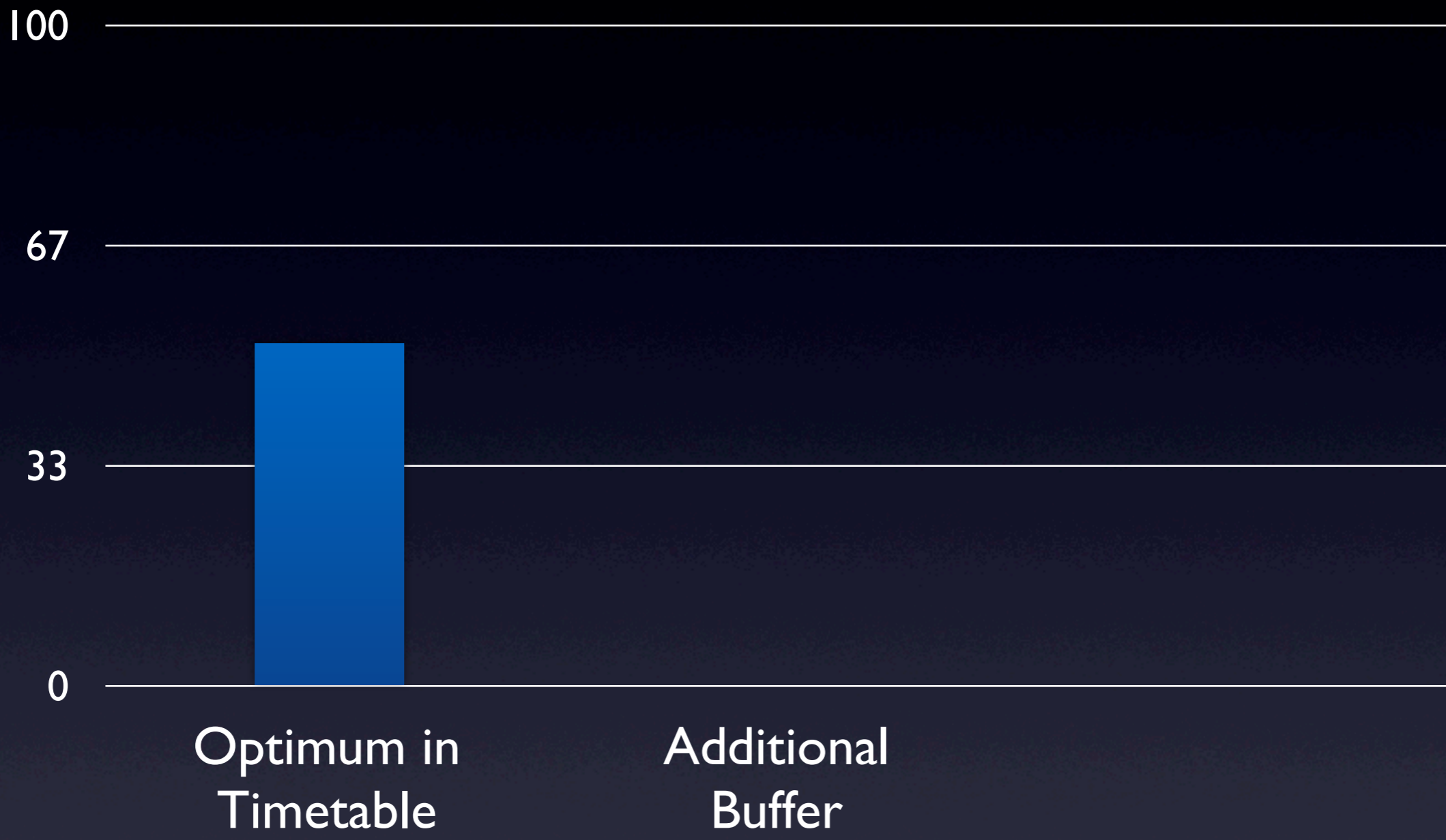

# Arrival Rates

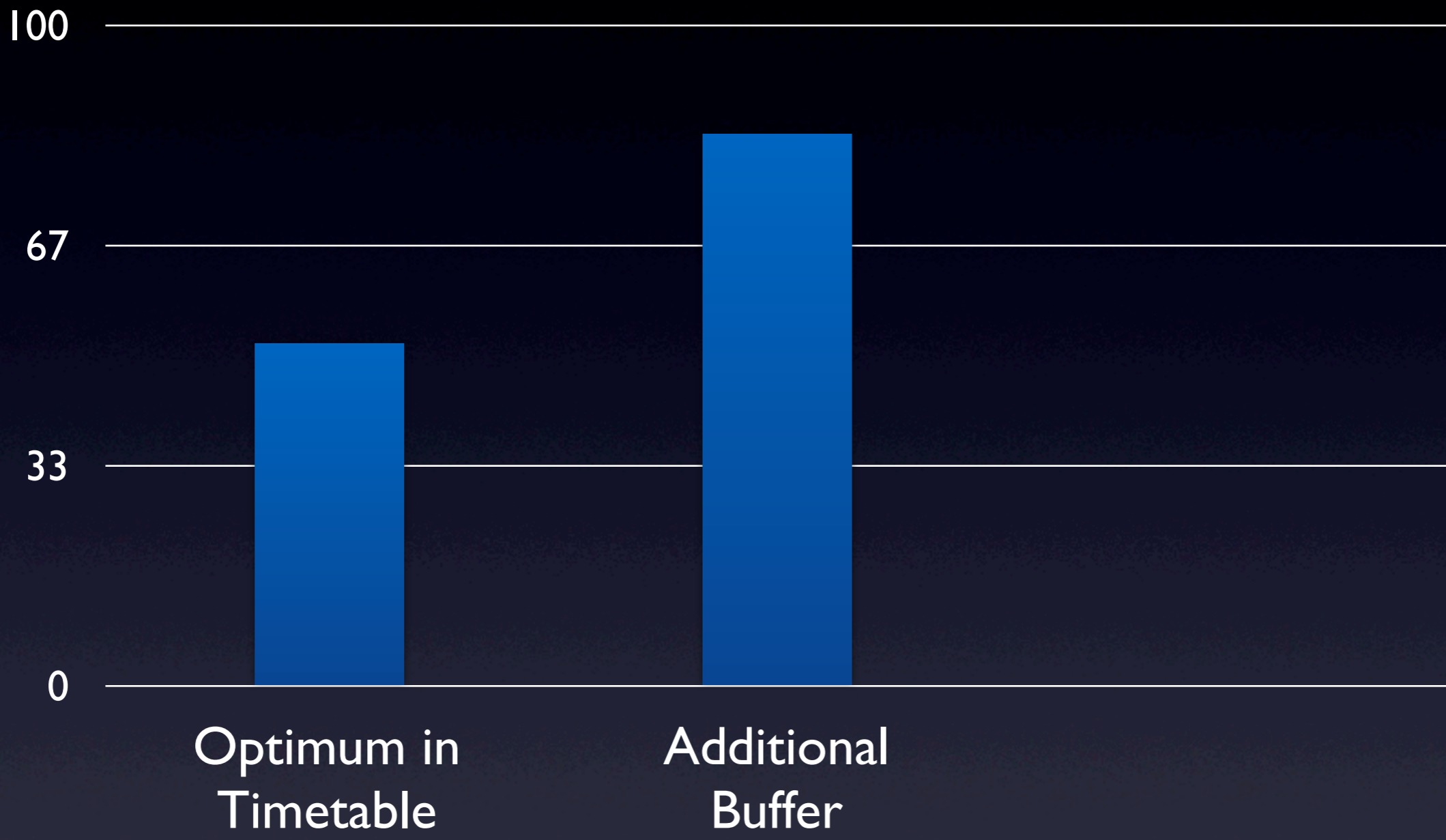

# Arrival Rates

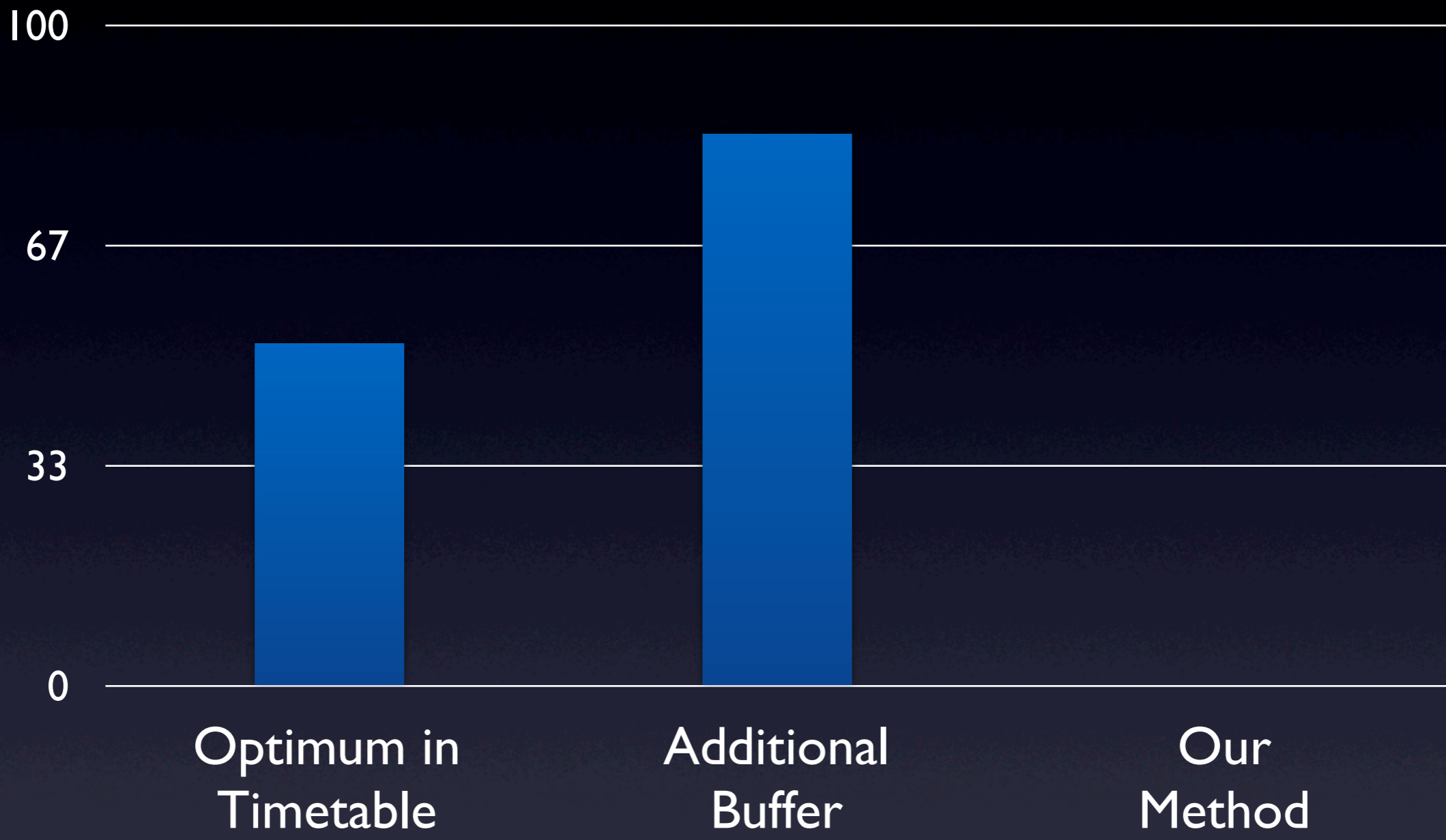

# Arrival Rates

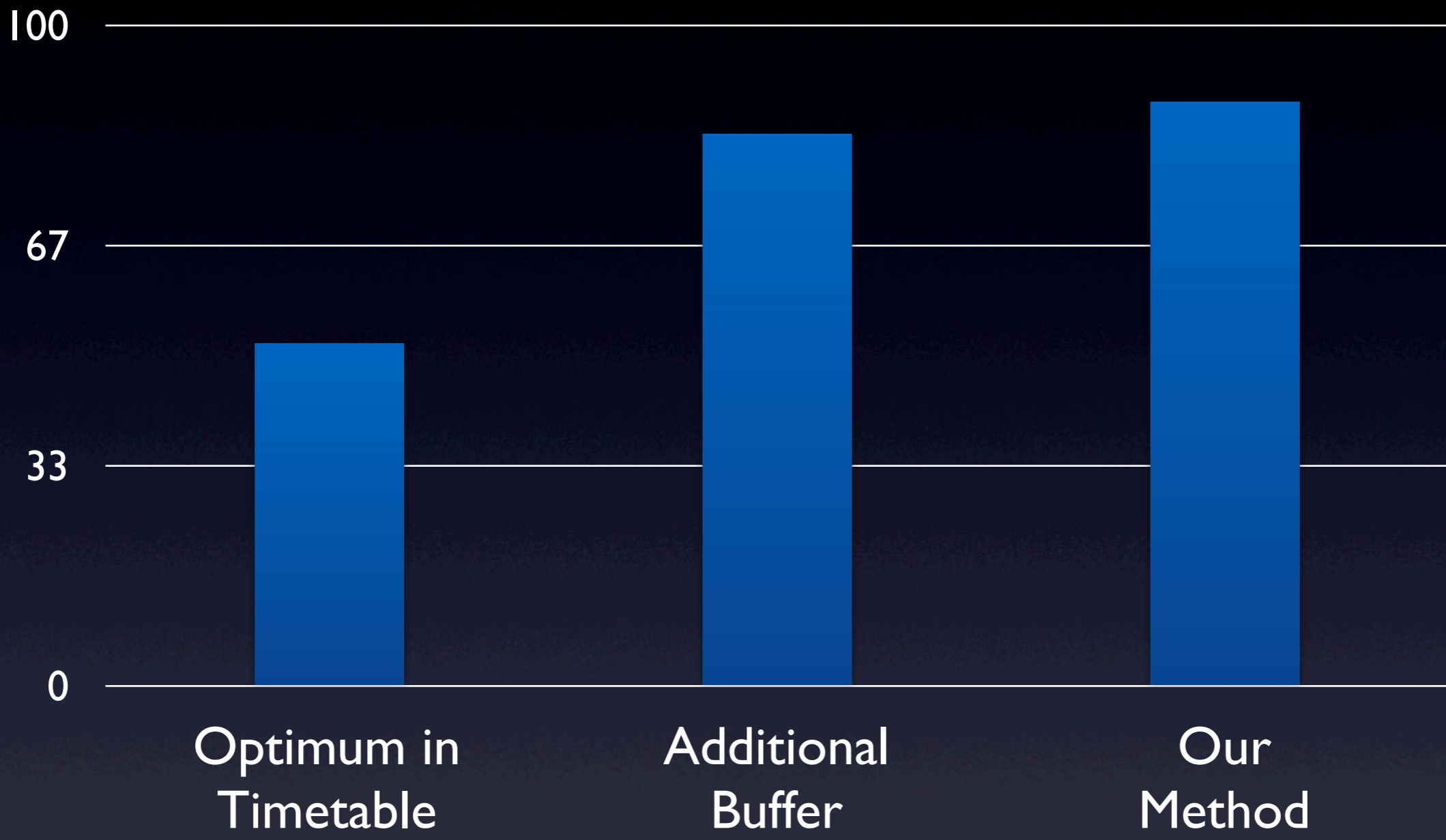

# Arrival Rates

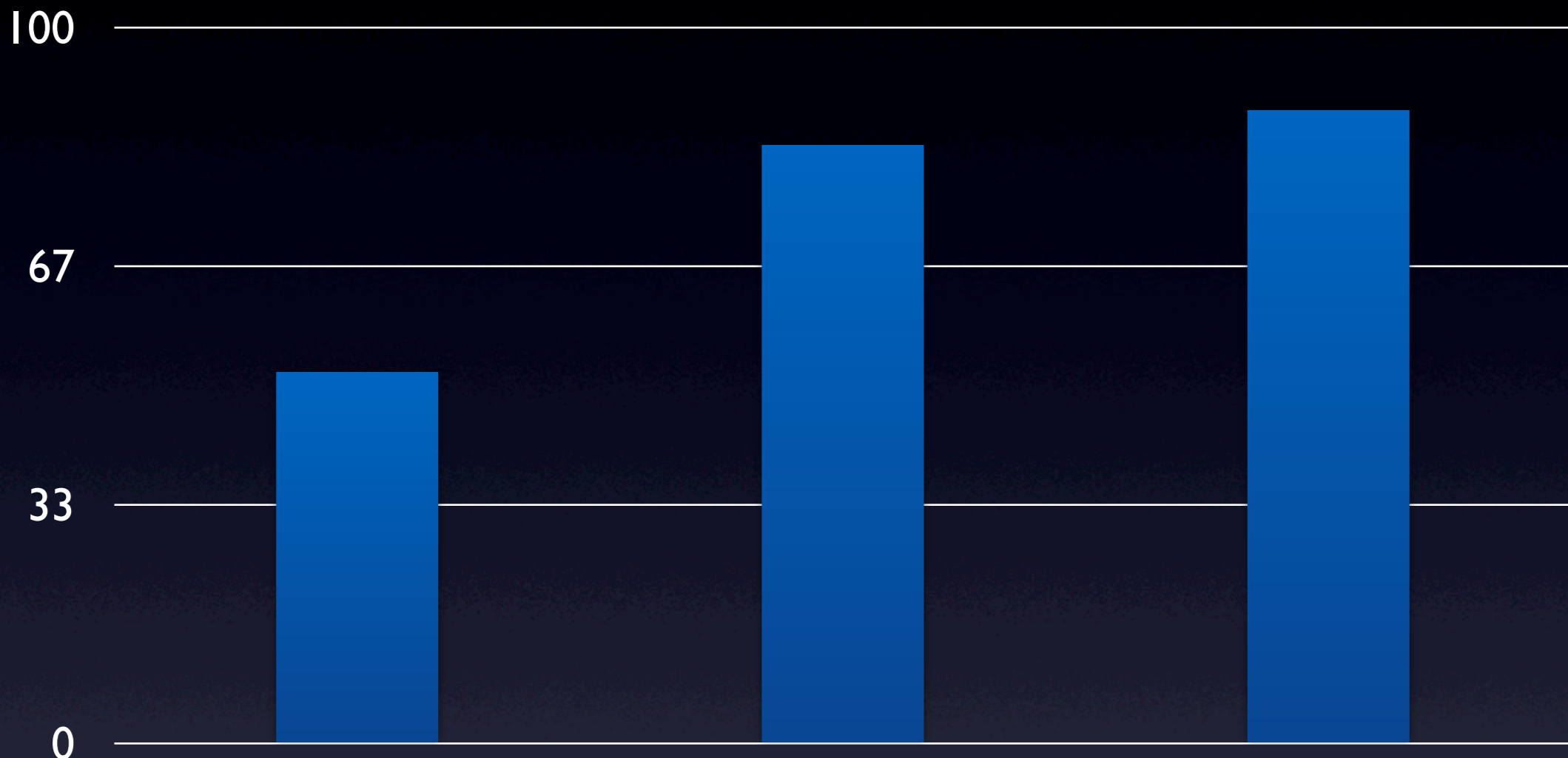

Optimum in  
Timetable

Additional  
Buffer

Our  
Method

7:28

7:20

7:20

# Line Types



# Line Types



Standard line

# Line Types



Standard line

Backward line



# Line Types



Standard line

Backward line

Line skipping  
certain stops

# Line Types

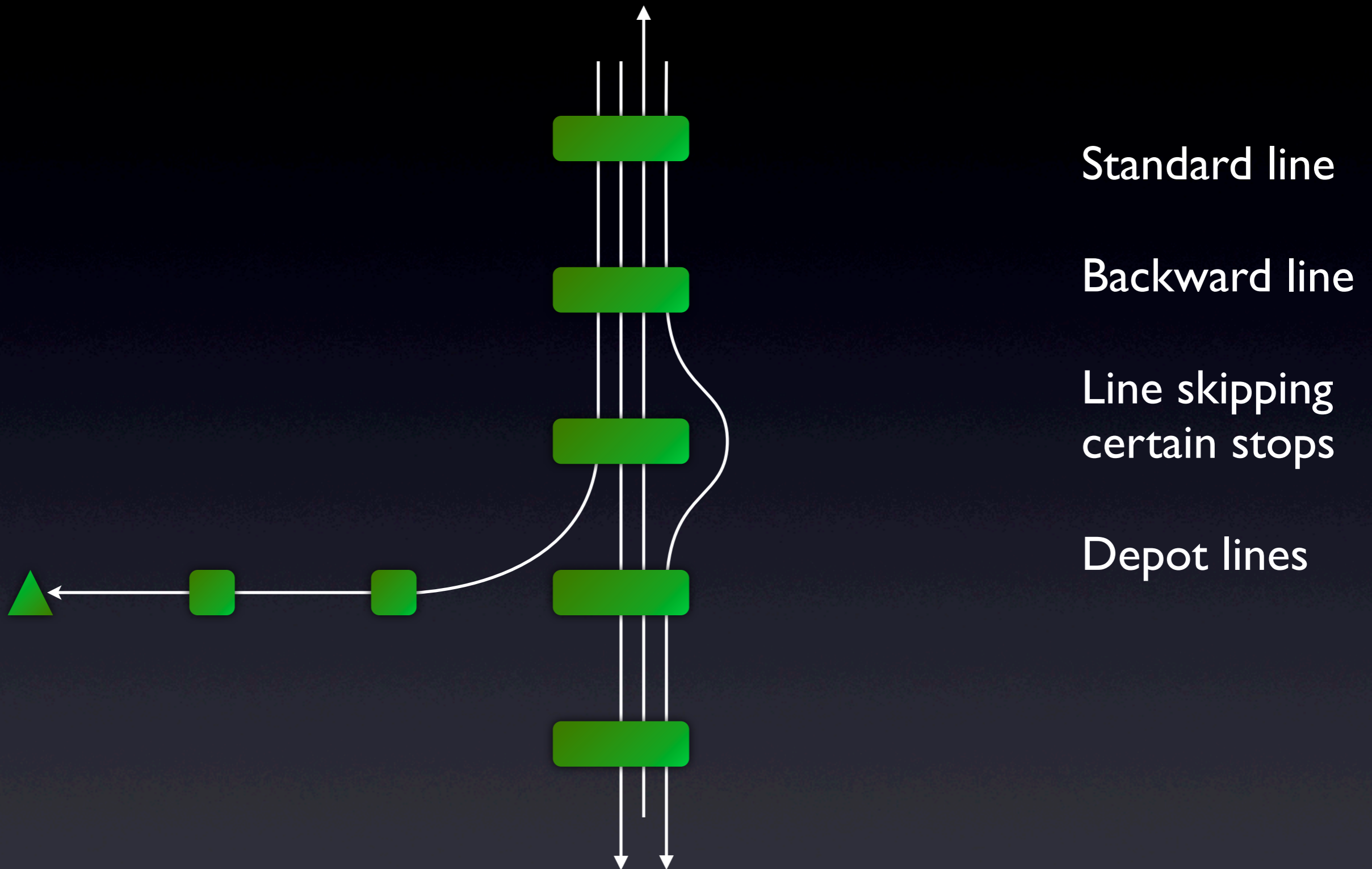

# Line Types

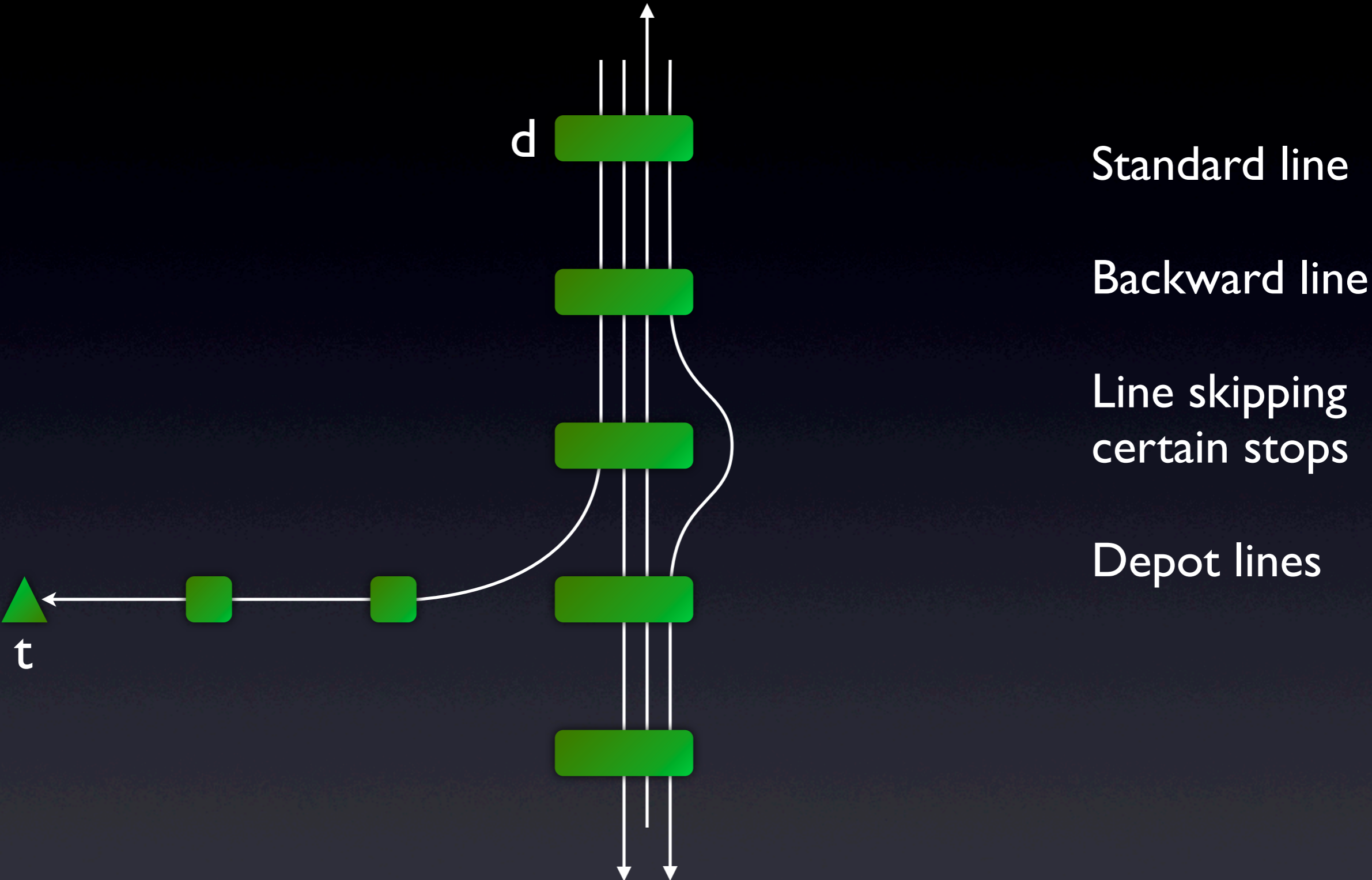

Standard line

Backward line

Line skipping certain stops

Depot lines

# Line Types

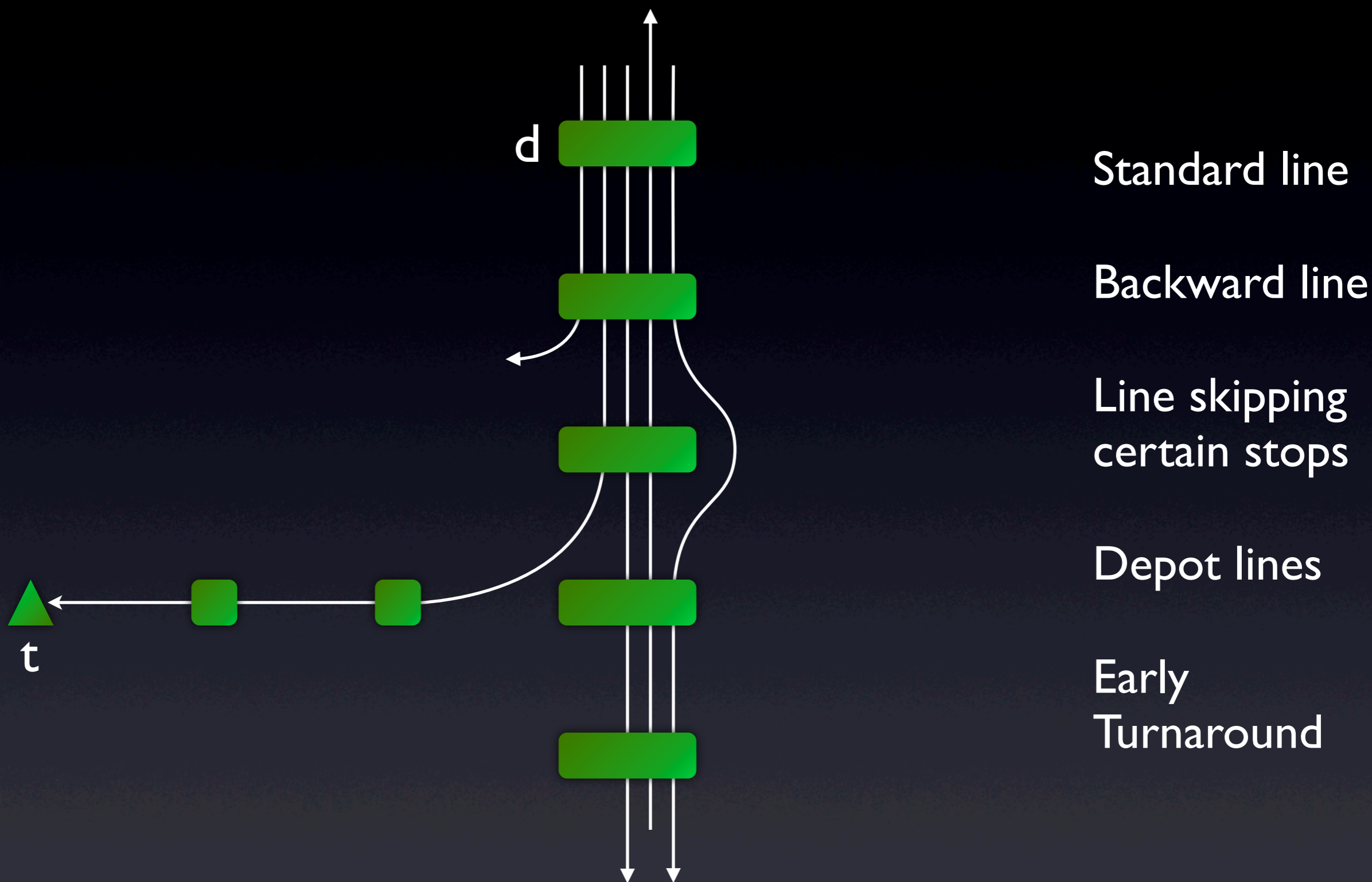

Standard line

Backward line

Line skipping certain stops

Depot lines

Early Turnaround

# Example

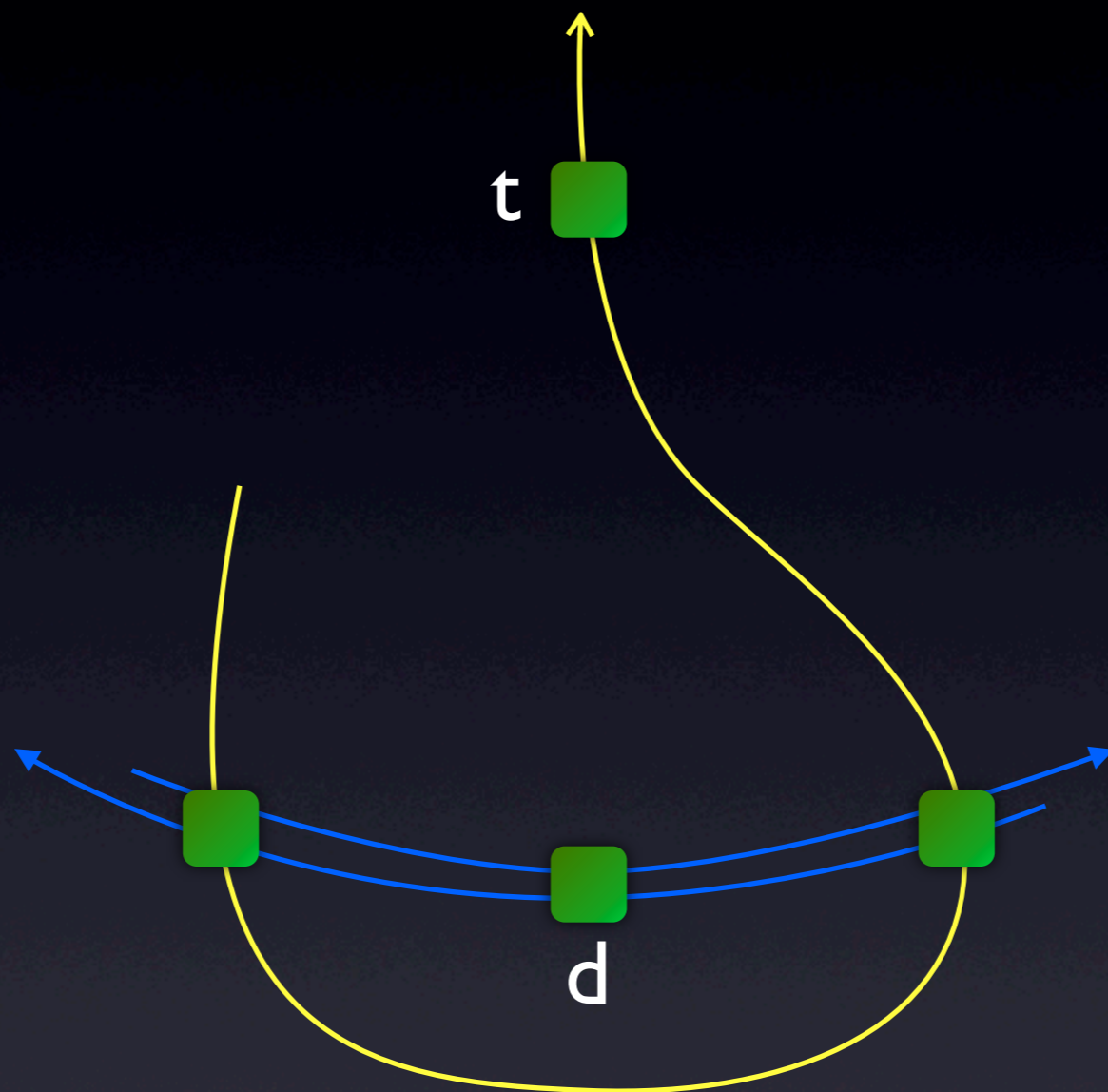

# Example

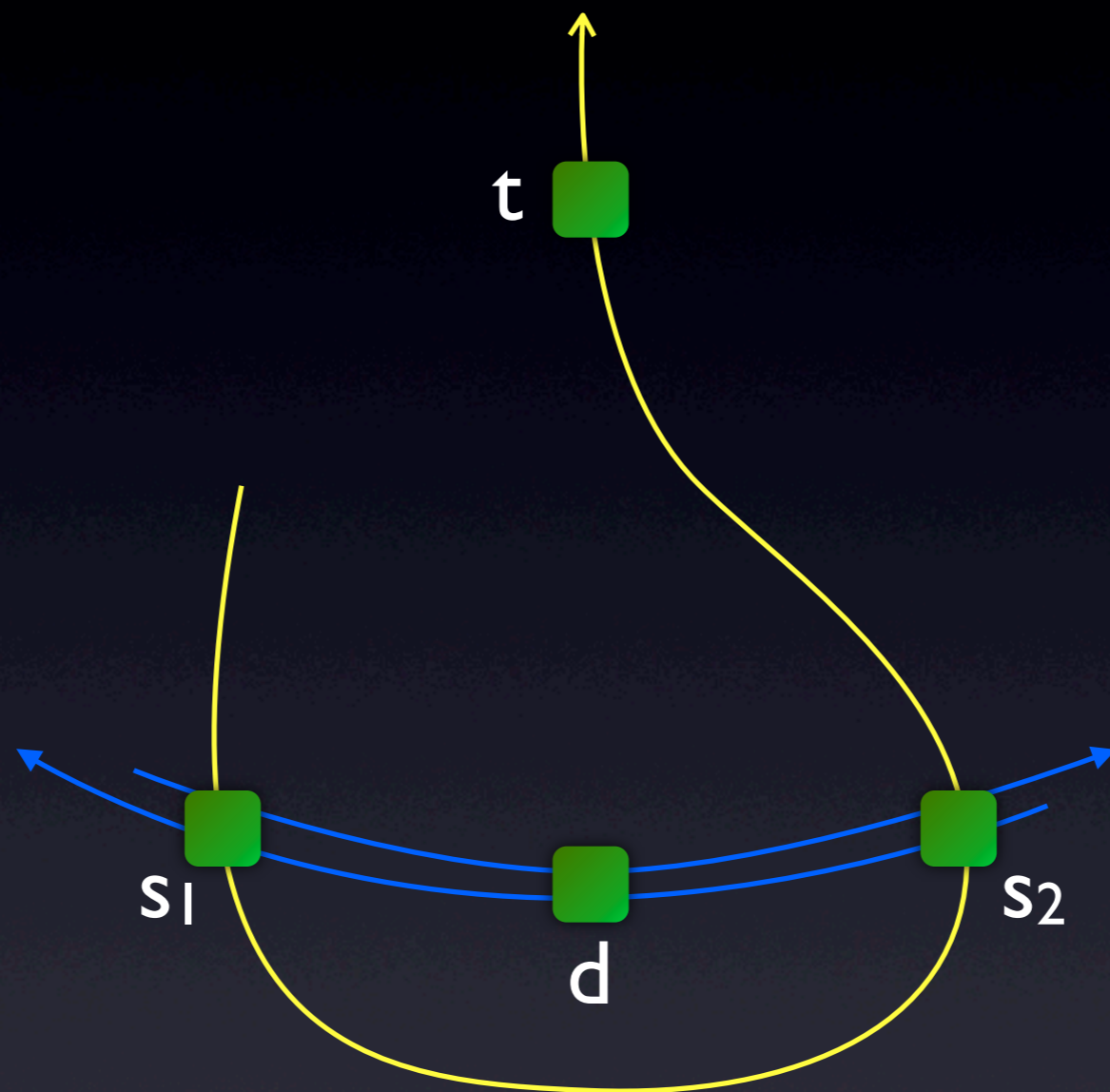

# Example

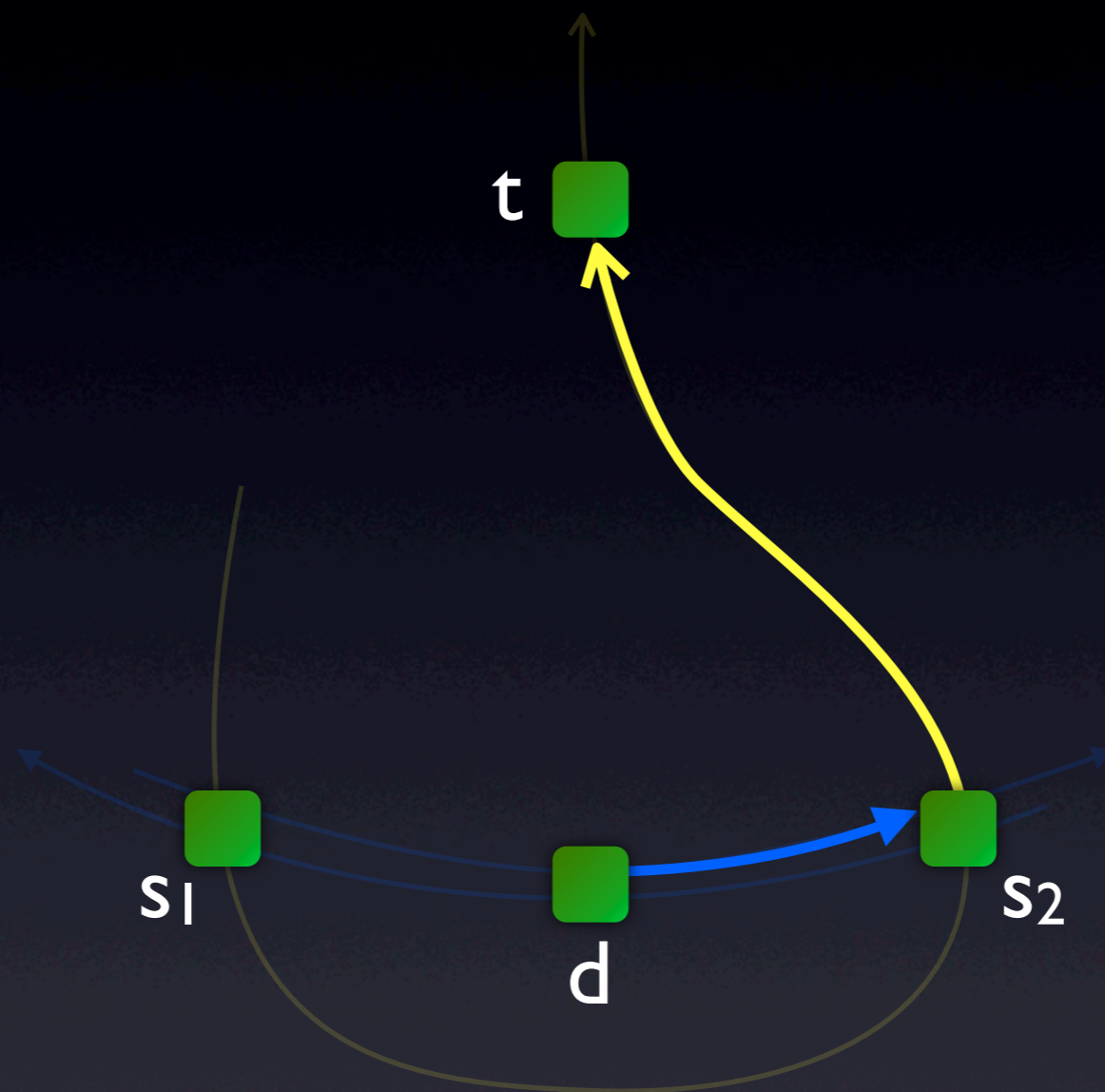

# Example

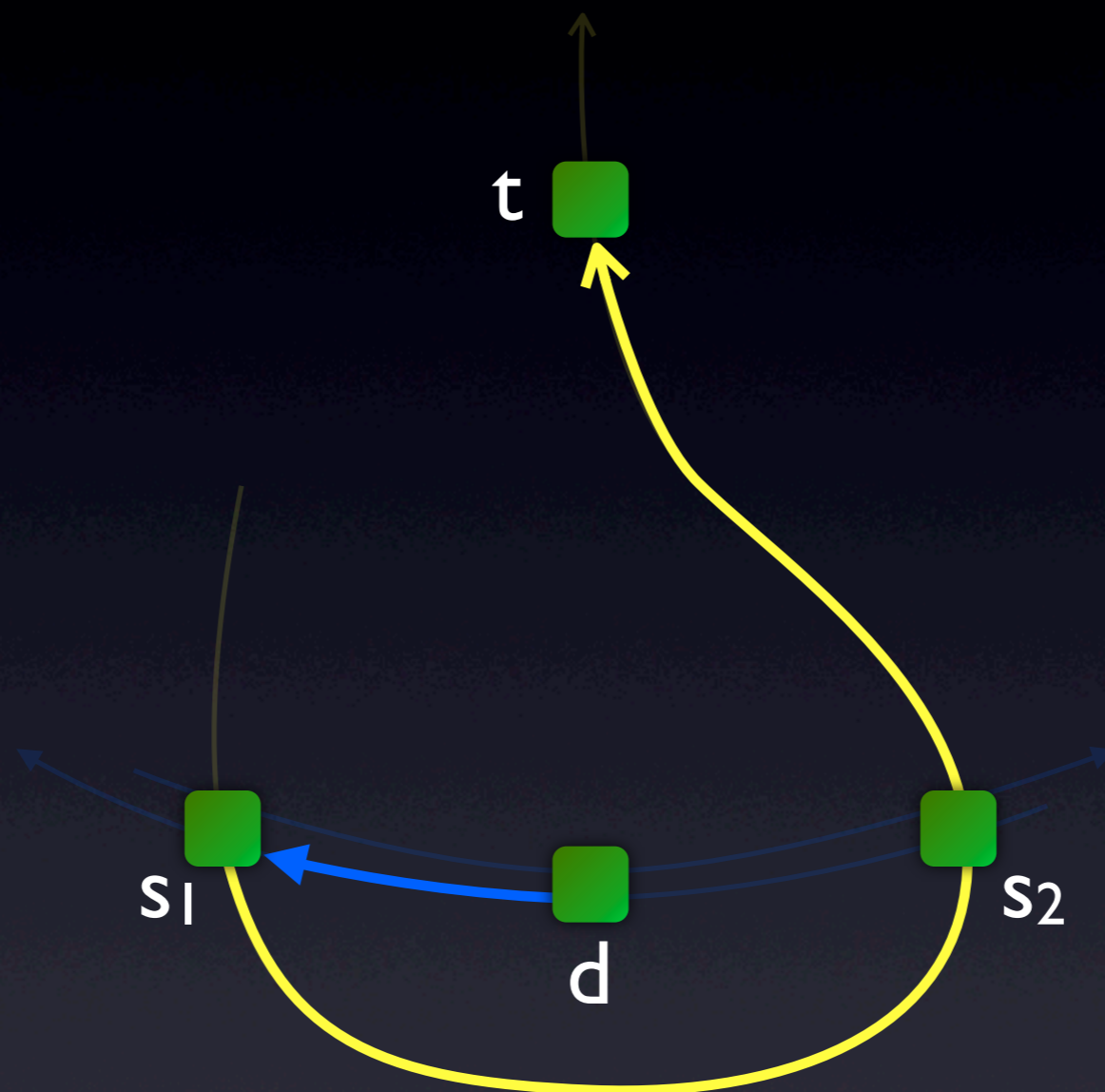



# Example

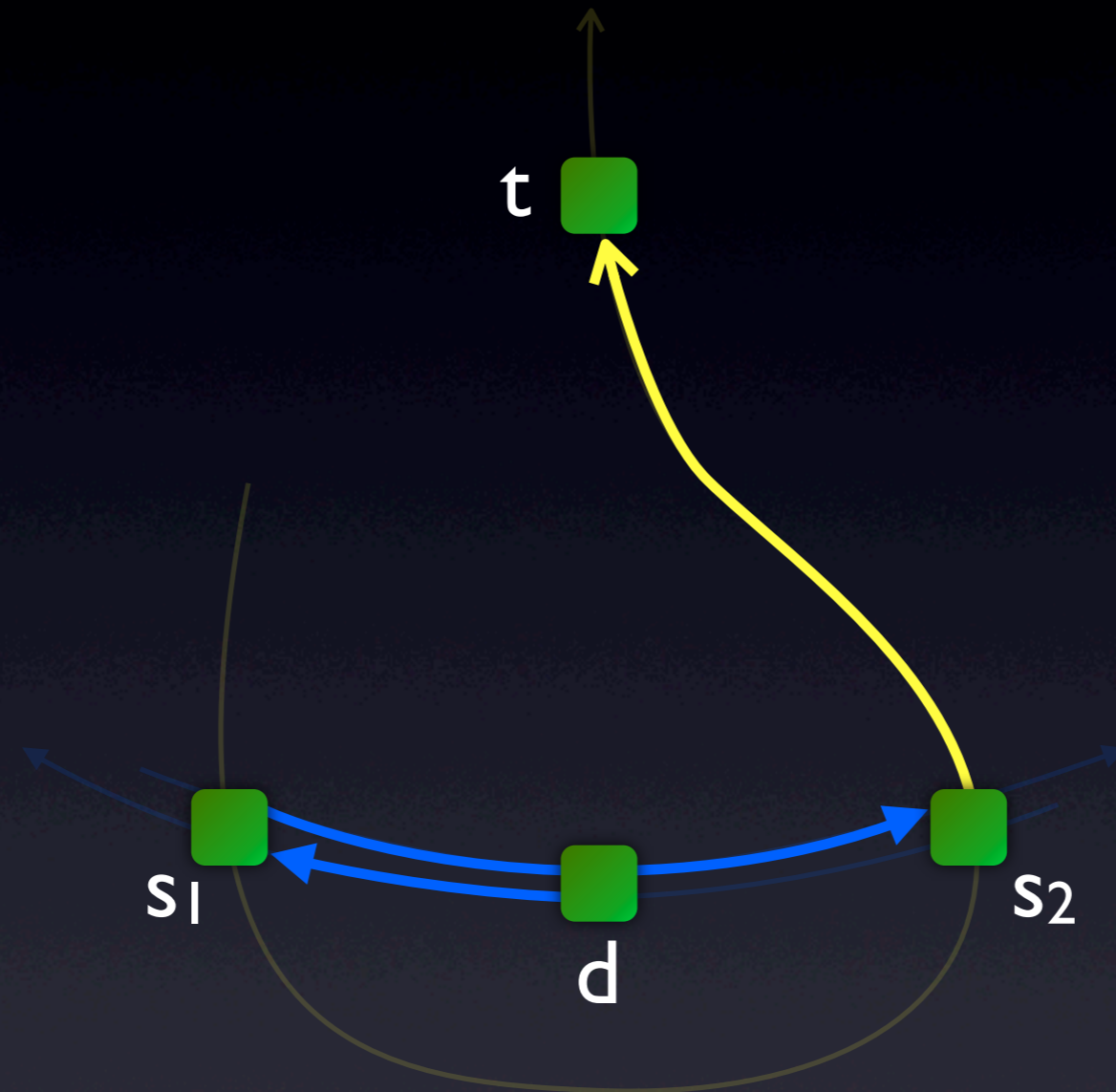

# Forward and Backward Line Differ

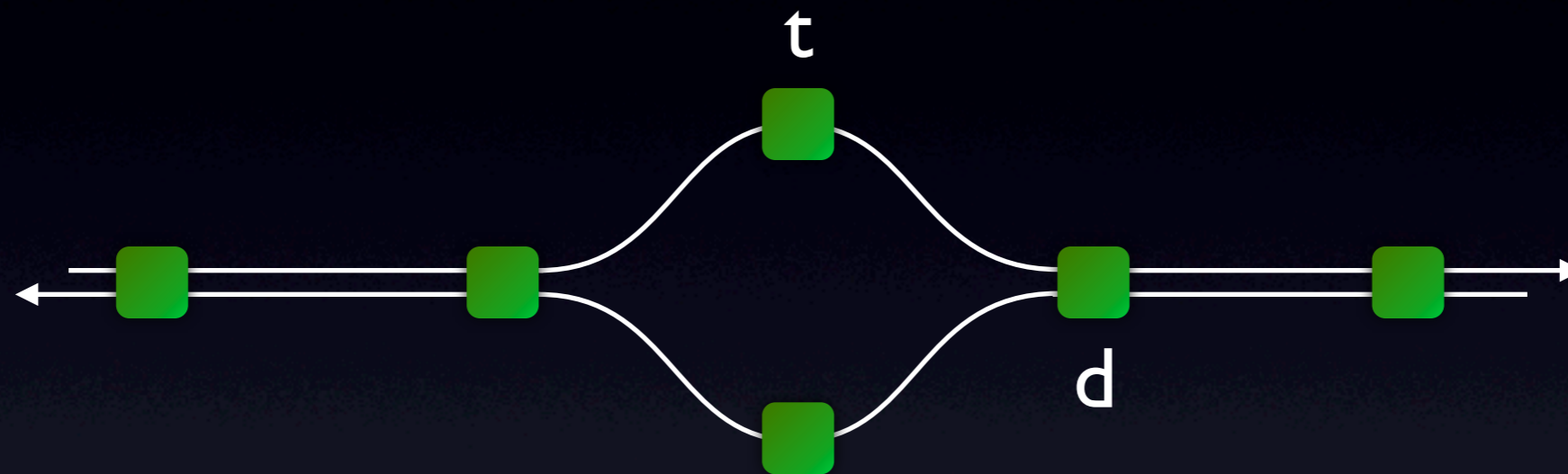

# Forward and Backward Line Differ

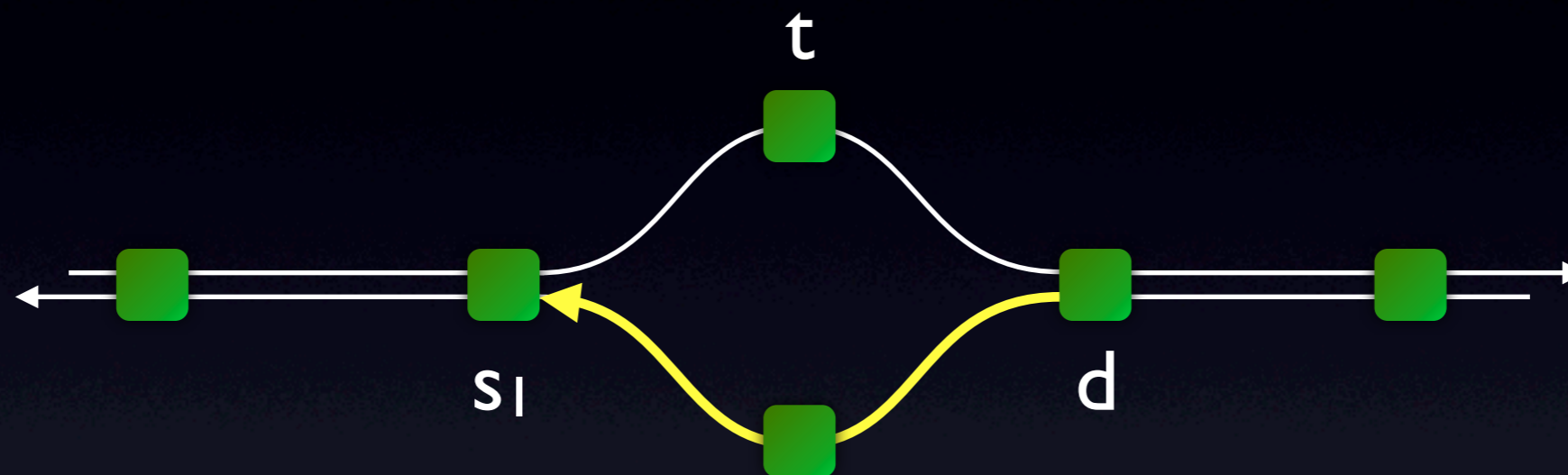

# Forward and Backward Line Differ

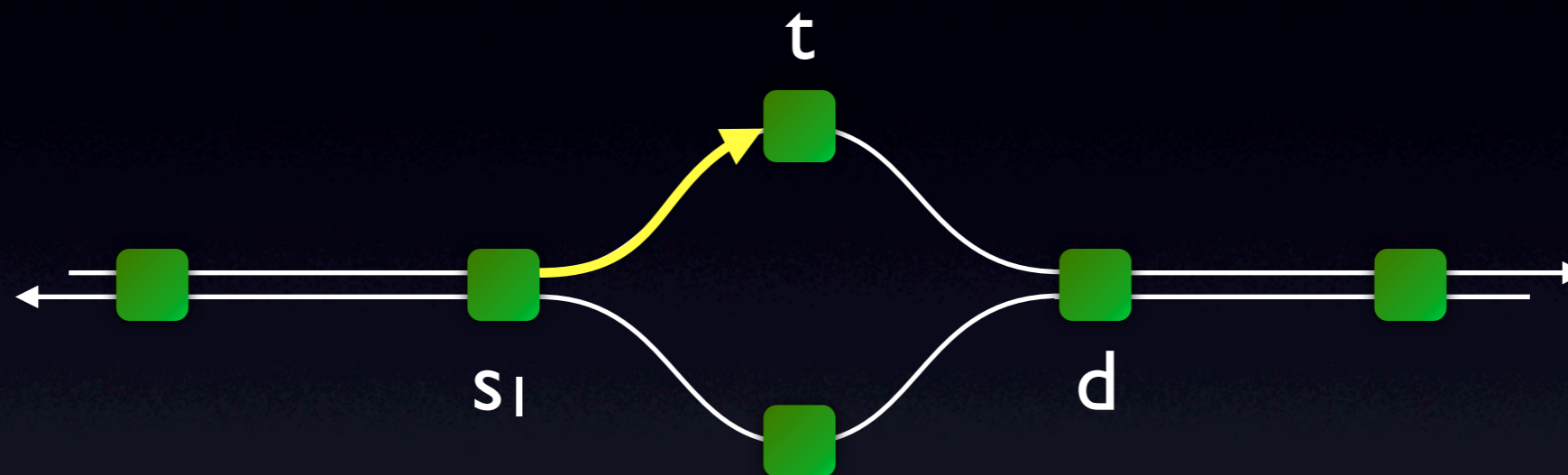

# Cyclic Line Ends

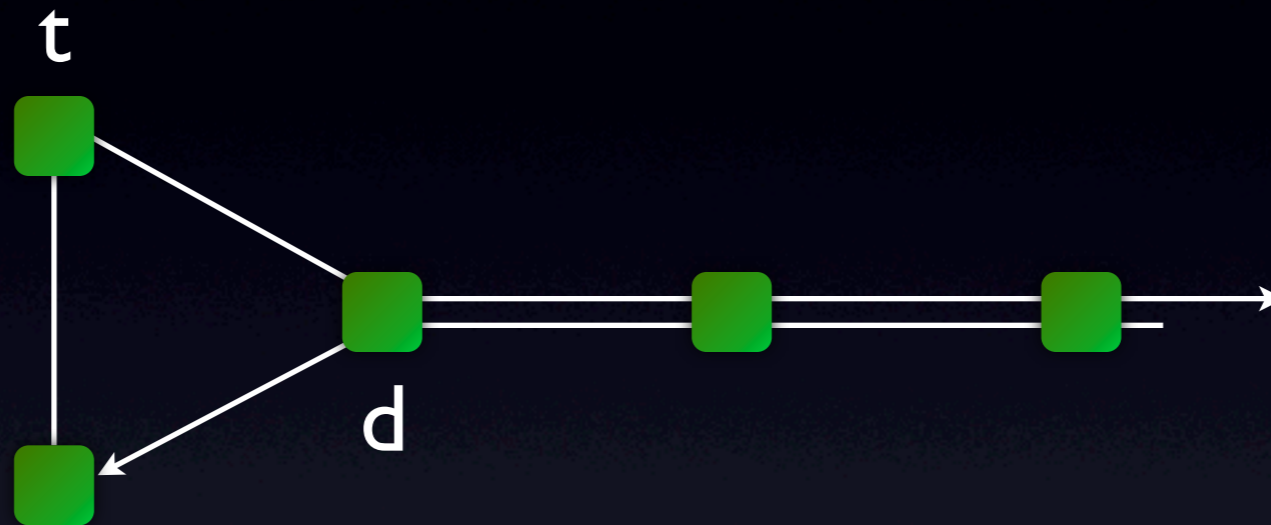

# Cyclic Line Ends

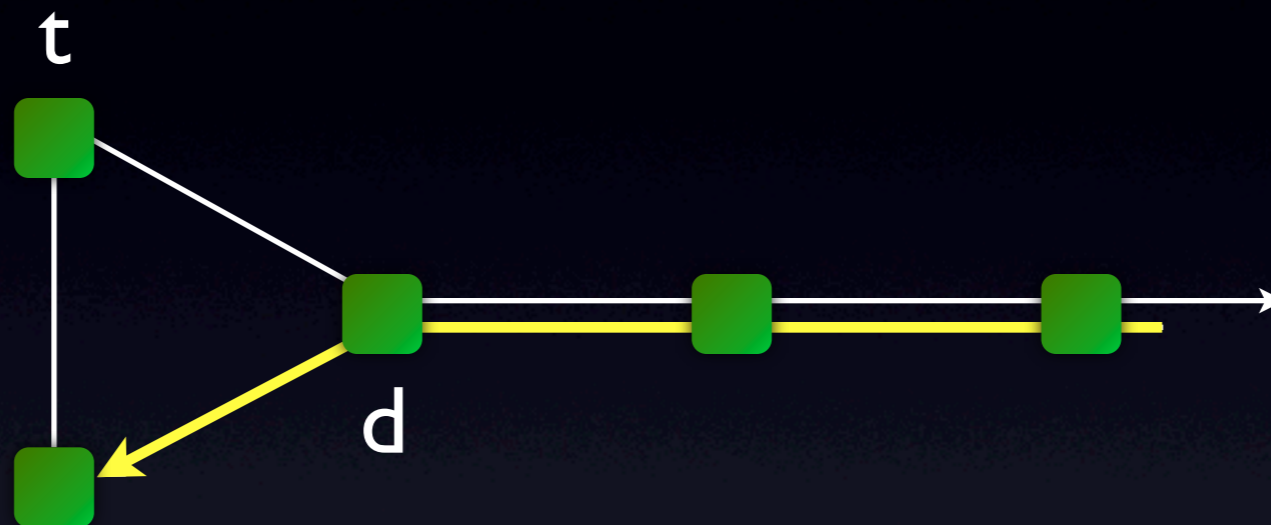

# Cyclic Line Ends

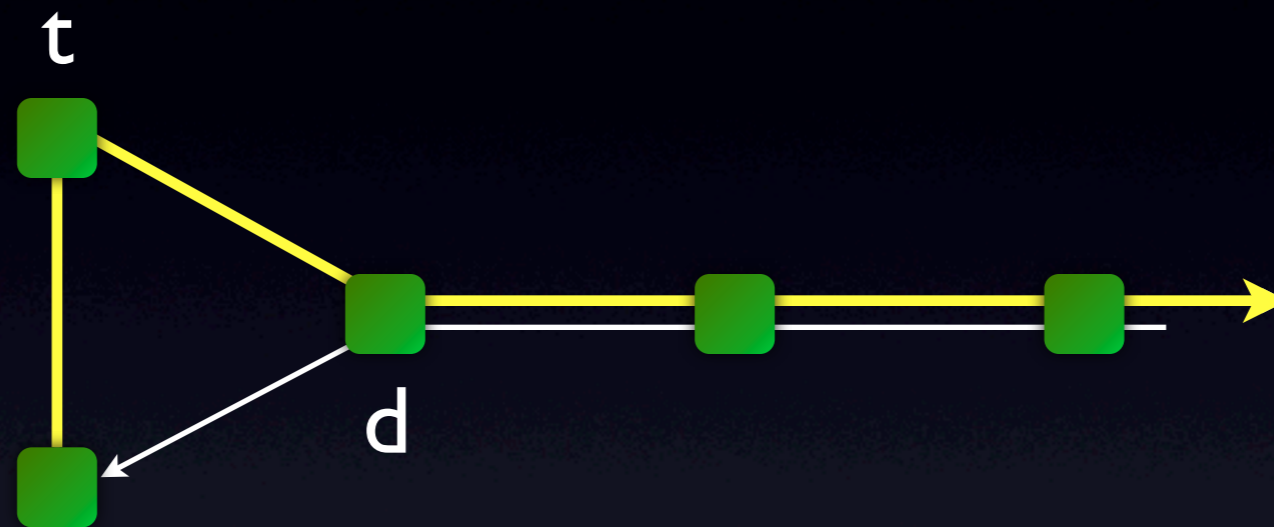

# Cyclic Line Ends

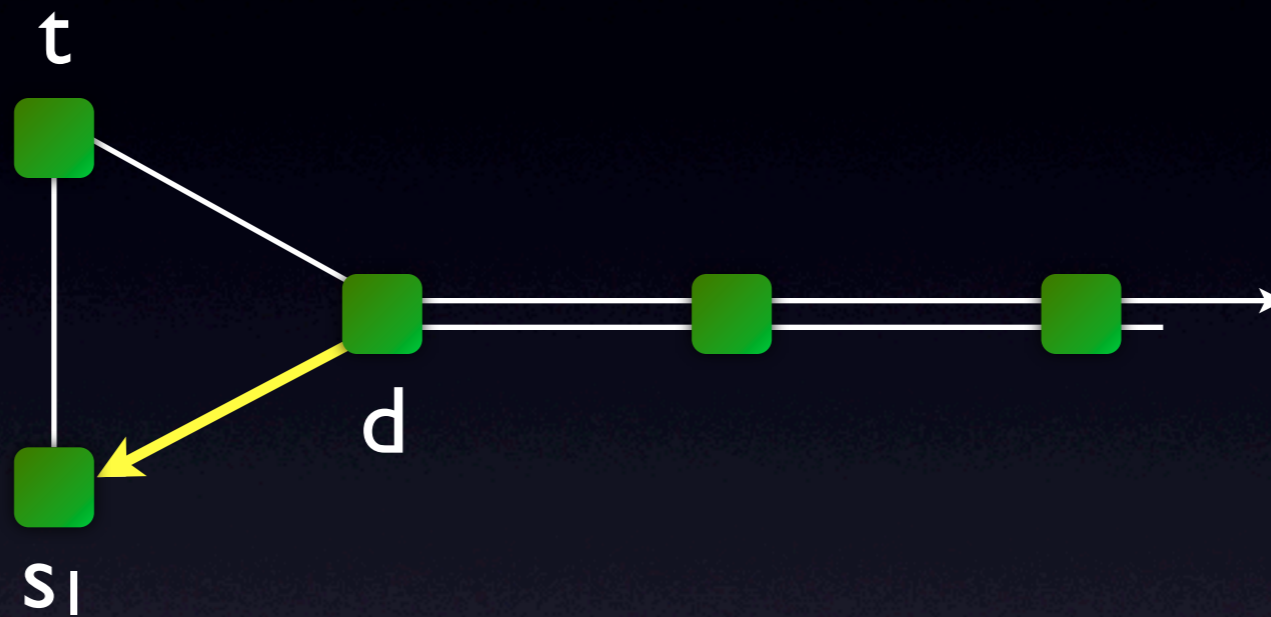



# Cyclic Line Ends

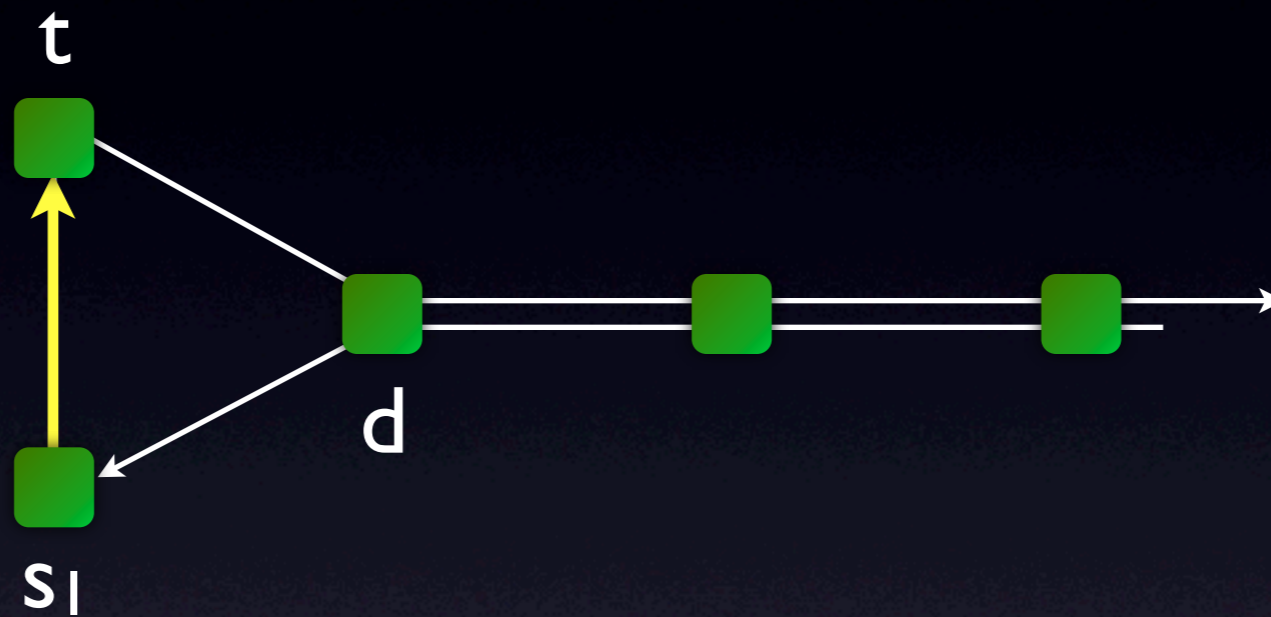

# Cyclic Lines

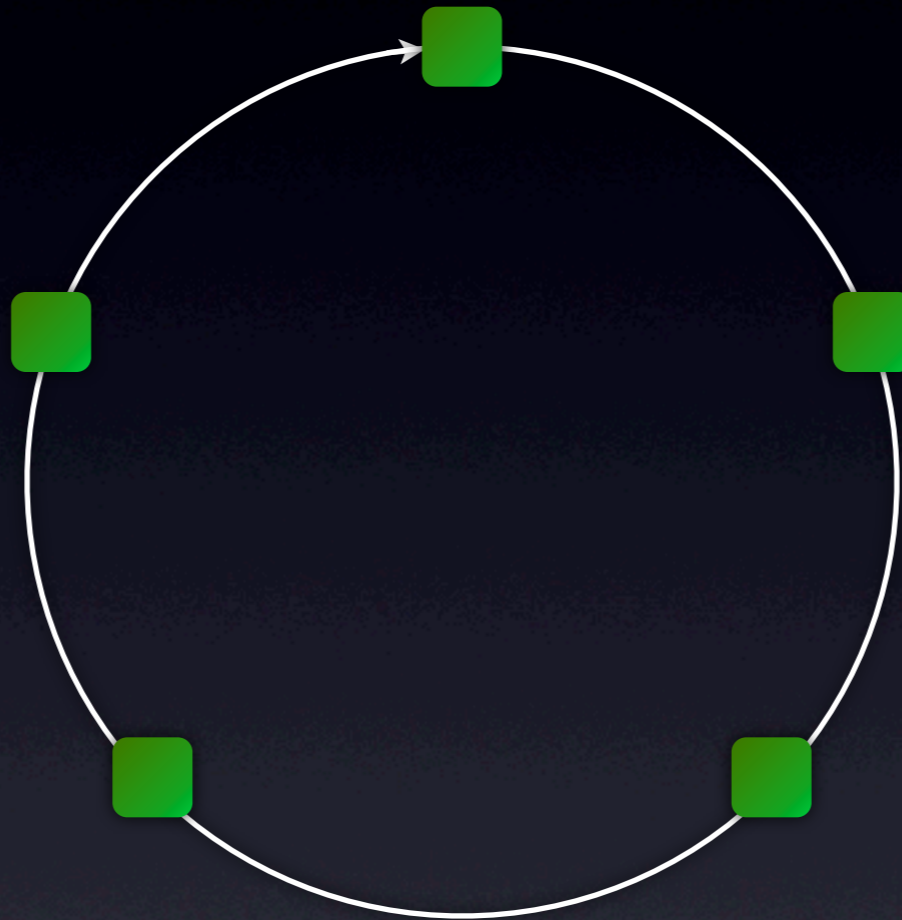

# Cyclic Lines

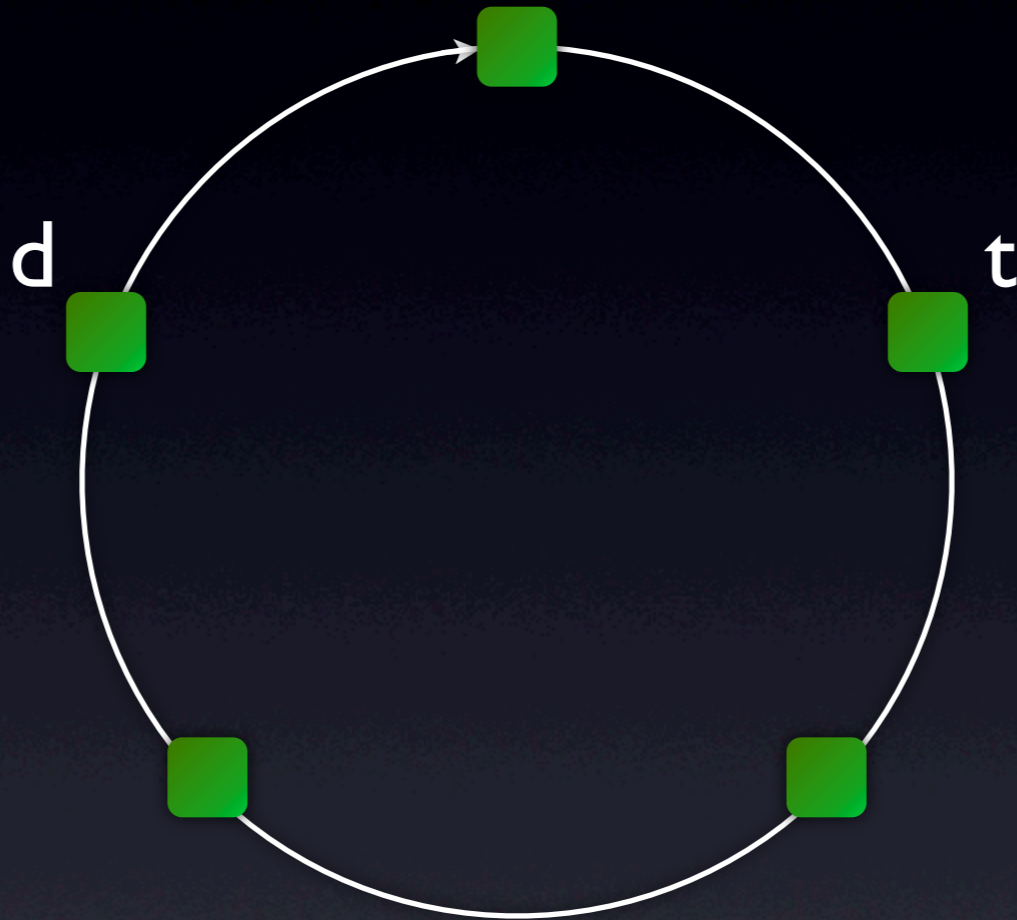

# Cyclic Lines

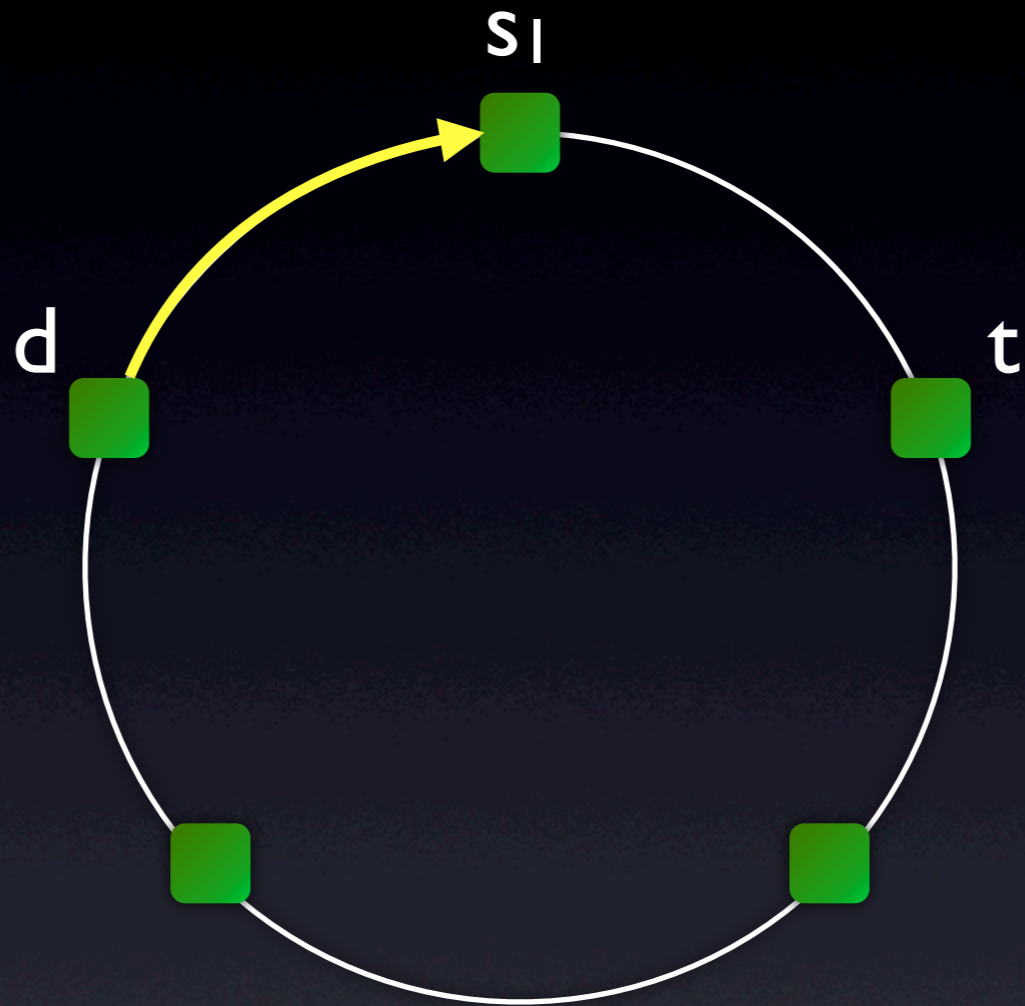

# Cyclic Lines

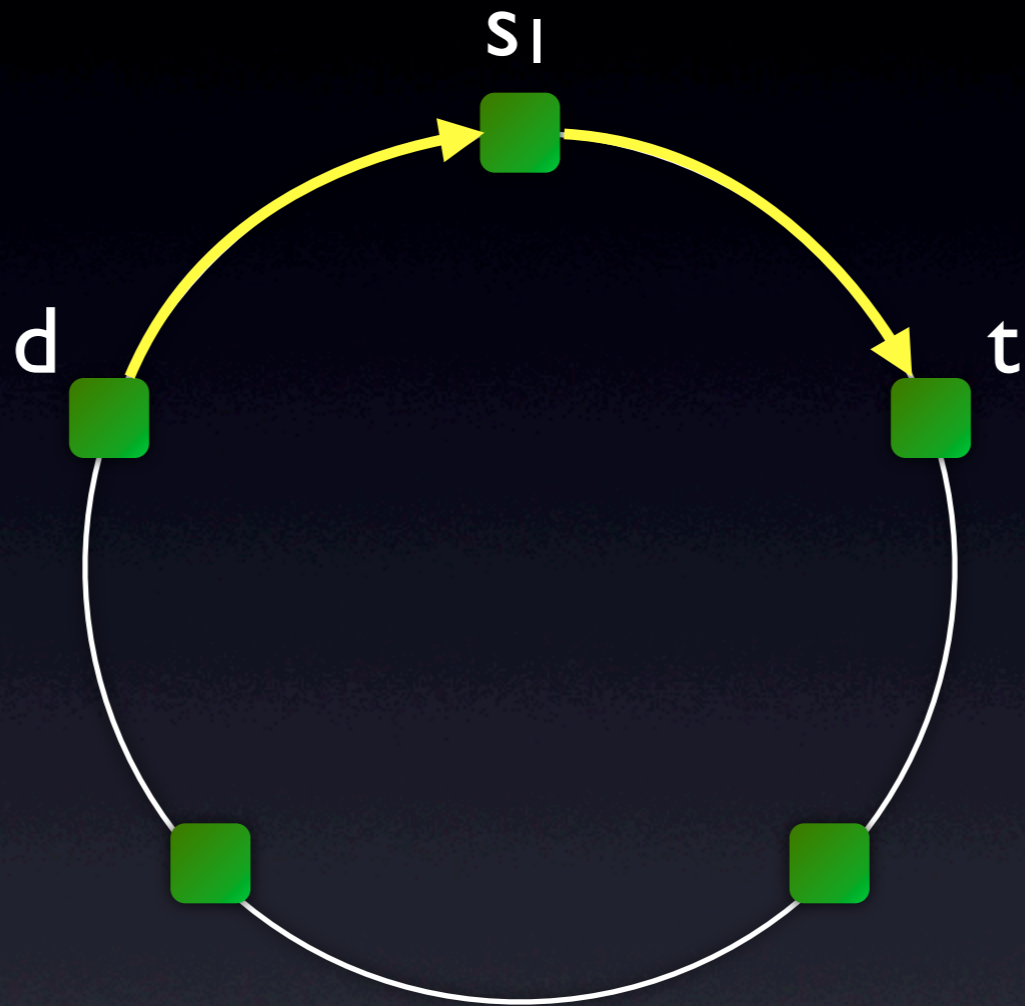

# Cyclic Lines

